

PANZITTA SALES & SERVICE
72 George Avenue
Wilkes-Barre, PA 18705
570-822-6720 800-822-6720
www.panzittasales.com

HD 1400E

Pezzi di ricambio / Spare parts list

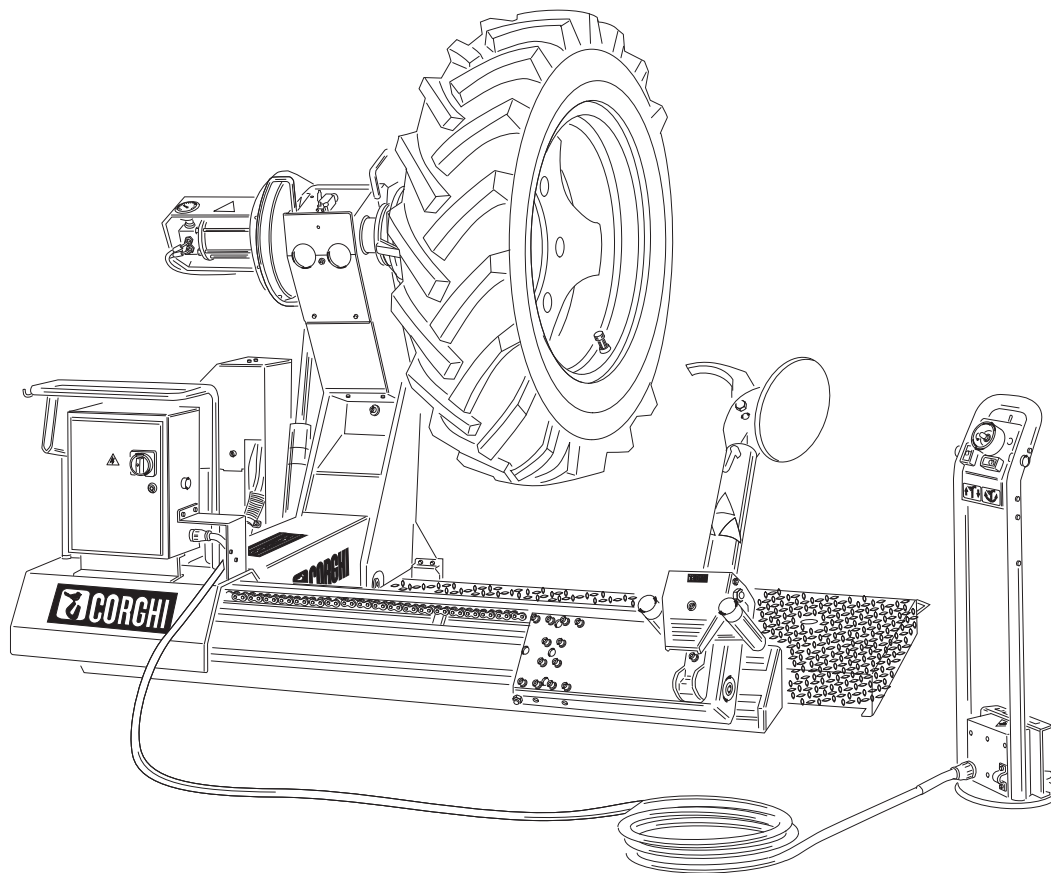

Code: 4-327933H

Production date: 02 / 2017



COMPLESSIVO HD I400E HD I400E OVERALL

PANZITTA SALES & SERVICE
72 George Avenue
Wilkes-Barre, PA 18705
570-822-6720 800-822-6720
www.panzittasales.com

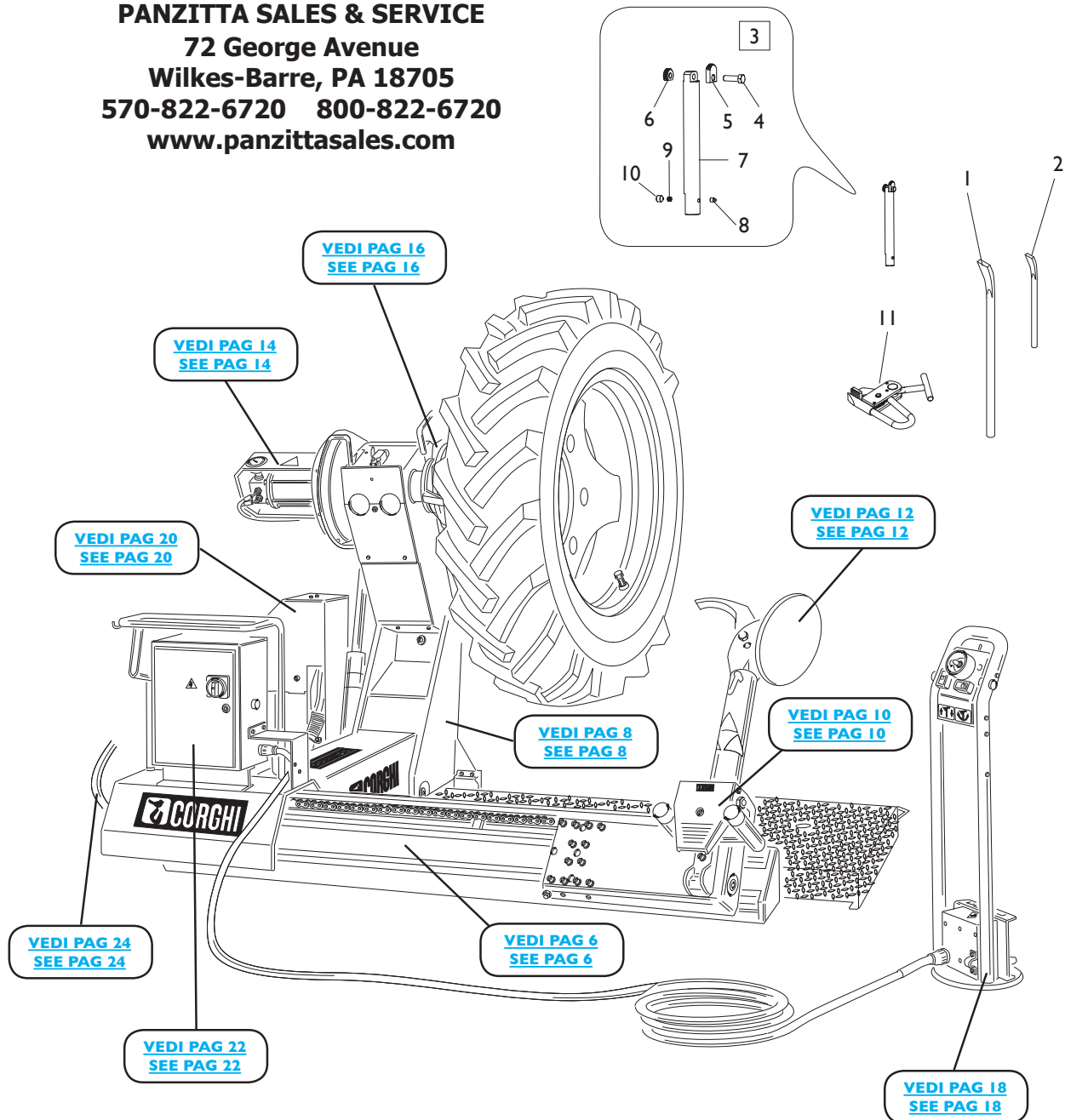

Rif. Ref.	Codice Code	Descrizione	Description
1	426388	LEVA ALZATALLONI CORTA	SHORT BEAD LEVER
2	236906	LEVA ALZATALLONI LUNGA	LONG BEAD LEVER
3	5-300329	KIT STELO GRIFFA 56"	EXTENTION ASSEMBLY
4	340844	VITE SPECIALE M12X39 1/2F	SPECIAL SCREW M12X39
5	418785	FERMO E GRIFFA	JAW
6	318784	GRIFFA	TOOL
7	4-327415	STELO D.35X315,5	EXTENTION 56" D.35X315,5
8	4-130128	GANCIO GRIFFA	HOOK JAW
9	401627	MOLLA D. 7,6X0,8X18	SPRING D. 7,6X0,8X18
10	2-20044	VSTEI M14X12	SCREW M14X12
11	219244	PINZA CERCHIONI	CLAMP RIMS

PANZITTA SALES & SERVICE
72 George Avenue
Wilkes-Barre, PA 18705
570-822-6720 800-822-6720
www.panzittasales.com

GRUPPO BASAMENTO BASE GROUP

PANZITTA SALES & SERVICE
72 George Avenue
Wilkes-Barre, PA 18705
570-822-6720 800-822-6720
www.panzittasales.com

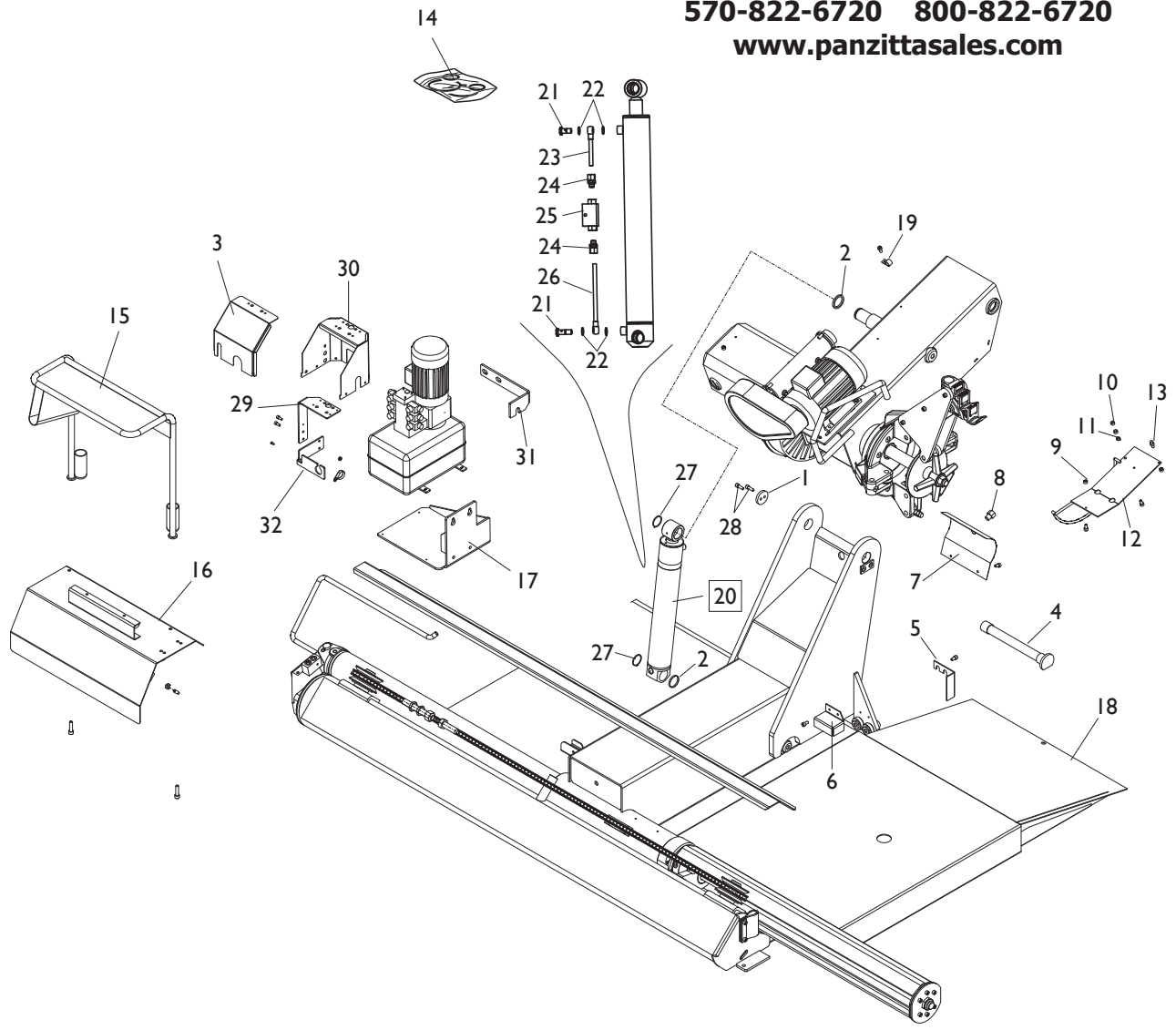

[TORNA AL COMPLESSIVO](#)
[RETURNS TO OVERALL](#)

Rif. Ref.	Codice Code	Descrizione	Description
1	341681	RONDELLA DOPPIO FORO D.12,5X60X8	TWO HOLES WASHER D.12,5X60X8
2	338751	RONDELLA D.40,5X51X4,5	WASHER D.40,5X51X4,5
3	4-327270	CARTER ANTERIORE	FRONT COVER
4	4-115836	PERNO BRACCIO MOBILE	MOBILE ARM PIN
5	342892	RASCHIATORE	SCRAPER
6	438544	CARENATURA ROTELLE	WHEEL COVER
7	342409	PROTEZIONE ROTONDA	COVER
8	3-02019	TAPPO TONDO D.20,6 H8,7	CAP D.20,6 H8,7
9	345883	CONTRASTO LAMIERA PER MICRO D.14	SPACER D.14
10	344485	TUBETTO LAMIERA MICRO D.8X24	SPACER D.8X24
11	439697	MOLLA D.10,2X38X0,9	SPRING D.10,2X38X0,9
12	245621	LAMIERA MICRO	MICRO PLATE
13	443794	ANTIVIBRANTE M/M 25X19 / 8X14	VIBRATION DAMPING M/M 25X19 / M8X14
14	242013	KIT GUARNIZIONI CIL. SOLL. BRACCIO	SEALS KIT FOR CYLINDER LIFT
15	4-326928	SUPPORTO IMPIANTO ELETTRICO	ELECTRIC SYSTEM SUPPORT
16	4-326512	BASAMENTO IMPIANTO ELETTRICO	ELECTRIC SYSTEM BASE
17	4-327202	SUPPORTO CENTRALINA	HYDRAULIC POWER SUPPORT
18	4-327371	PEDANA STANDARD	STANDARD RAMP
19	441731	COLLARE D.25	COLLAR D.25
20	5-105073	CILINDRO SOLL. BRACCIO	LIFT CYLINDER ASSEMBLY
21	495021	VITE CAVA 1/4	SCREW 1/4
22	495678	RONDELLA 1/4	WASHER 1/4
23	398458	TUBO D.10 L.55mm	HOSE D.10 L.55mm
24	495779	RACCORDO 1/4 T.10	FITTING 1/4 T.10
25	462559	VALVOLA RITEGNO	RELIEF VALVE
26	498418	TUBO D.10 L.250mm	HOSE D.10 L.250mm
27	2-00792	SEEGER D.40	SEEGER D.40
28	2-02096	VSTEI M12X20	SCREW M12X20
29	4-327268	SUPPORTO CARTER ELETTRICALE	SUPPORT
30	4-327269	CARTER POSTERIORE ELETTRICALE	REAR COVER
31	4-327421	STAFFA FISSAGGIO MOTORE	MOTOR BRACKET
32	4-327424	STAFFA SUPPORTO CAVI	CABLE BRACKET

PANZITTA SALES & SERVICE
72 George Avenue
Wilkes-Barre, PA 18705
570-822-6720 800-822-6720
www.panzittasales.com

GRUPPO STRUTTURA MOBILE MOBILE STRUCTUR GROUP

PANZITTA SALES & SERVICE
72 George Avenue
Wilkes-Barre, PA 18705
570-822-6720 800-822-6720
www.panzittasales.com

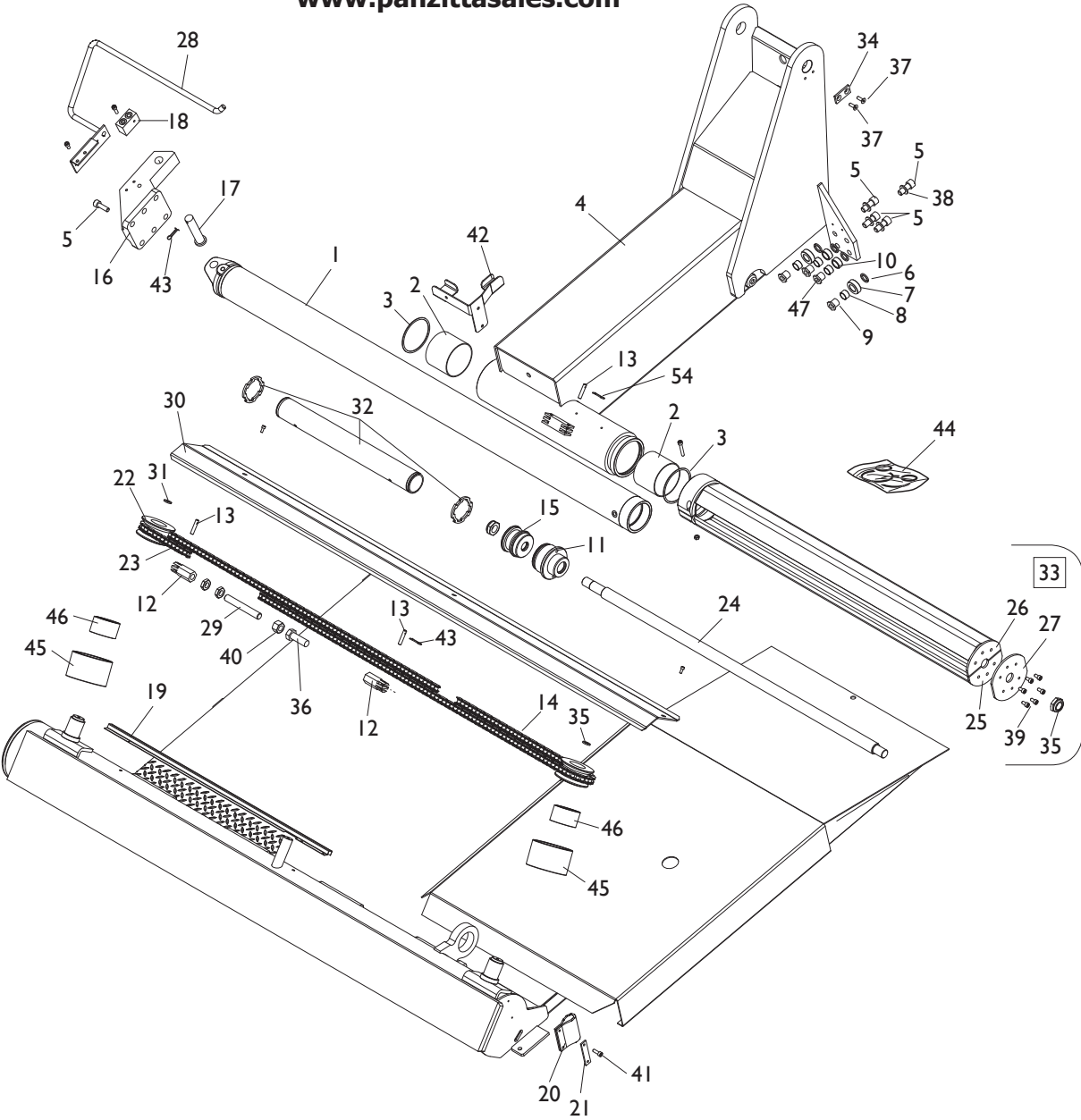

**TORNA AL COMPLESSIVO
RETURNS TO OVERALL**

Rif. Ref.	Codice Code	Descrizione	Description
1	4-326245	FONDELLO CON CAMMA D.85	LINER D.85
2	438762	BRONZINA D.104,6X110X80	BUSH D.104,6X110X80
3	442417	GUARNIZIONE D.105X117,2X6,5	SEAL D.105X117,2X6,5
4	4-115837	BRACCIO FISSO	ARM
5	2-01901	VTCEI M16X40	HEXAGON SOCKET HEAD SCREW M16X40
6	338755	RONDELLA D.22,1X30X3,5	WASHER D.22,1X30X3,5
7	338753	RONDELLA D.25X44X15	WASHER D.25X44X15
8	3-00622	BOCCOLA D.22X15	BUSH D.22X15
9	338752	PERNO ROTELLA	WHEEL PIN
10	338754	RONDELLA D.25X32X15	WASHER D.25X32X15
11	338687	FLANGIA ANTERIORE D.85	FRONT FLANGE D.85
12	338733	TENDI CATENA	CHAIN TENSOR
13	339217	PERNO CATENA	CHAIN PIN
14	439634	CATENA 77 MAGLIE L.1956	CHAIN L.1956
15	338682	STANTUFFO	PISTON
16	355058	APPOGGIO CILINDRO	CYLINDER PLATE
17	338732	PERNO CILINDRO	CYLINDER PIN
18	340202	BLOCCHETTO DI DEVIAZIONE	BLOCK
19	343022	PROTEZIONE TUBO	HOSES COVER
20	342882	GOMMA PROTEZIONE	RUBBER
21	341448	TRAFILATO CORTO	SHORT PLATE
22	240982	PULEGGIA	PULLEY
23	4-109357	CATENA INFERIORE 59"	LOWER CHAIN 59"
24	4-326247	STELO	STEM
25	4-326249	TIRANTE INFERIORE	LOWER TIE ROD
26	4-326248	TIRANTE SUPERIORE	UPPER TIE ROD
27	339297	ANELLO ANTERIORE TIRANTE	FRONT TIE ROD
28	4-326921	SUPPORTO TUBI	HOSES SUPPORT
29	4-326962	TIRANTE D.20X140 M20	TIE ROD D.20X140 M20
30	338387	CARTER CATENA	CHAIN COVER
31	338712	RONDELLA D.35X55X7	WASHER D.35X55X7
32	241401	TUBO	PIPE
33	4-326244	CILINDRO COMPLETO D.85	CYLINDER ASSEMBLY D.85
34	4-115839	PIATRINO ANTIROTAZIONE	STOP PLATE
35	2-01902	DADO ES.B.A. M27X2	LOWER AUTOLOCKING HEX. NUT M27X2
36	2-03404	VTE M20X60	HEXAGON HEAD SCREW M20X60
37	2-02674	VTSPEI M12X35	SCREW M12X35
38	2-01045	RONDELLA D.16	WASHER D.16
39	2-01906	VTCEI M12X25	HEXAGON SOCKET HEAD SCREW M12X25
40	2-01134	DADO ES.A. M20	AUTOLOCKING HEXAGON NUT M20
41	2-71331	VTCEI M5X45	HEXAGON SOCKET HEAD SCREW M5X45
42	4-326774	SUPPORTO GUAINA	SUPPORT
43	2-01044	COPIGLIA D.2,5X20	PLIT PIN D.2,5X20
44	242014	KIT GUARNIZIONI CIL. D.85	CYLINDER D.85 SEALS KIT
45	2-03759	BOCCOLA D.40X45X30	BUSH D.40X45X30
46	2-03760	BOCCOLA D.40X45X20,5	BUSH D.40X45X20,5
47	4-300222	BOCCOLA ECCENTRICA	ECCENTRIC BUSH

GRUPPO BRACCIO STALLONATORE BEAD BREAKING GROUP

PANZITTA SALES & SERVICE
72 George Avenue
Wilkes-Barre, PA 18705
570-822-6720 800-822-6720
www.panzittasales.com

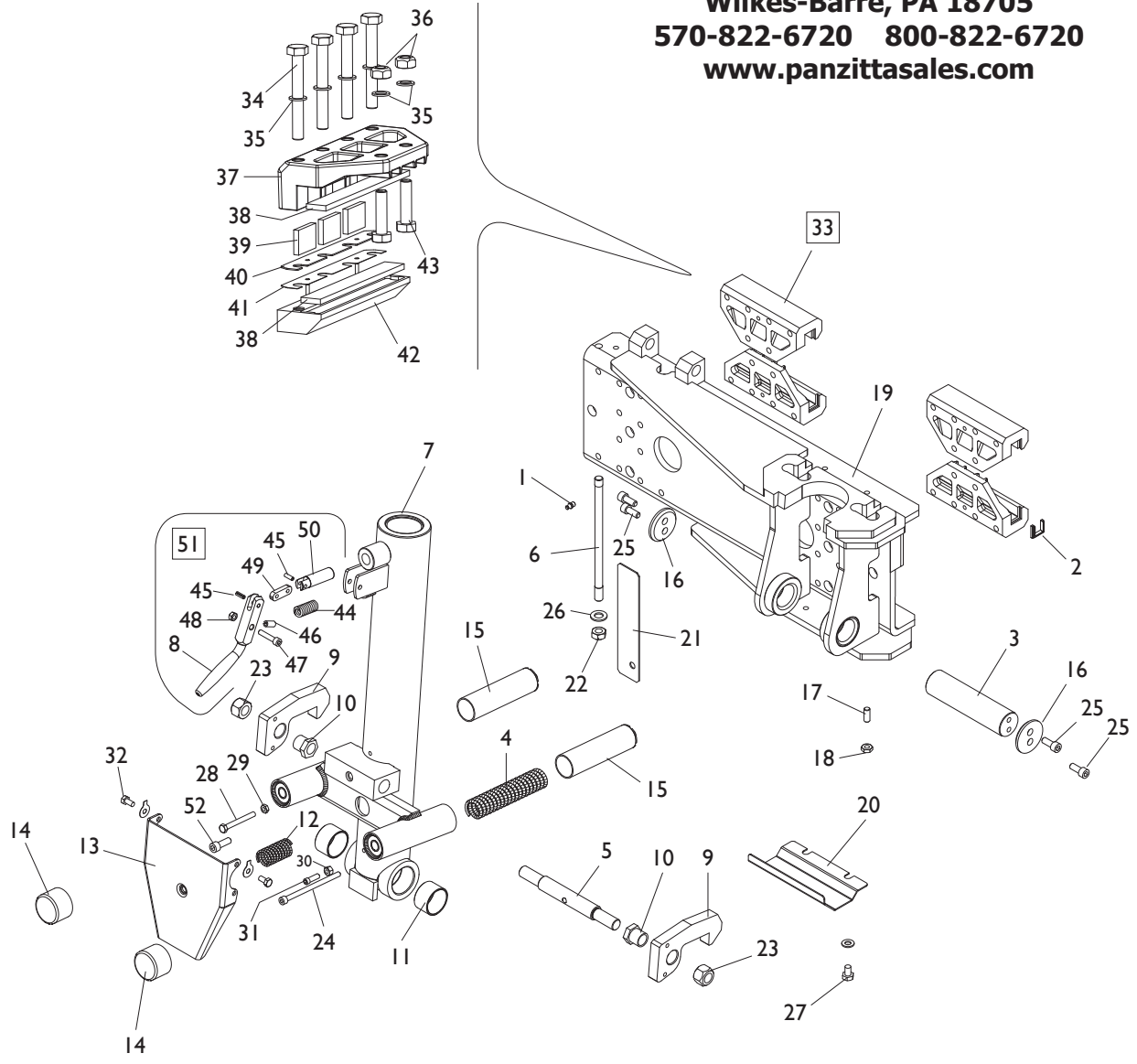

**TORNA AL COMPLESSIVO
 RETURNS TO OVERALL**

Ref.	Code	Descrizione	Description
1	439580	INGRASSATORE M8	GREASER M8
2	438416	RASCHIAPOLVERE	SCREAPER
3	4-327208	PERNO INC. BRACCIO UTENSILE	ARM PIN
4	437519	MOLLA D.36X245X5,2	SPRING D.36X245X5,2
5	338461	PERNO ECCENTRICO	ECCENTRIC PIN
6	342356	TIRANTE	TIE-ROD
7	4-121486	BRACCIO UTENSILI	BEAD BREAKER ARM
8	3006289	LEVA CHIAVISTELLO	TOOL RETAINER
9	4-327206	CRICCHETTO LAVORATO	HOOK
10	338463	PERNO ECCENTRICO GANCIO D.25X29	ECCENTRIC PIN D.25X29
11	3-00629	BOCCOLA D.45X30	BUSH D.45X30
12	443754	MOLLA D.27X3,2X82	SPRING D.27X3,2X82
13	343755	PEDALE	PEDAL
14	443756	CAPPUCCIO DI PROTEZIONE PER TUBI	PROTECTION CAP
15	243751	FODERO MOLLA	SPRING HOLDER
16	341681	RONDELLA DOPPIO FORO D.12,5X60X8	TWO HOLES WASHER D.12,5X60X8
17	2-01291	VSTEI M10X25	SCREW M10X25
18	2-00169	DADO ES. M10	HEXAGON NUT M10
19	4-327209	CARRELLO	CARRIAGE
20	4-327205	CARTER PROTEZIONE	COVER
21	4-327422	PIATTO CONTRASTO TAMPONE	PAD PLATE
22	421674	DADO ES.A. M14	AUTOLOCKING HEXAGON NUT M14
23	422677	DADO ES.A. M20	AUTOLOCKING HEXAGON NUT M20
24	2-94039	VTCEI M8X130	HEX. SOCKET HEAD SCREW M8X130
25	2-01191	VTCEI M10X25	HEXAGON SOCKET HEAD SCREW M10X25
26	2-00215	RONDELLA D.14	WASHER D.14
27	2-80040	VTE M10X16	HEXAGON HEAD SCREW M10X16
28	2-00377	VTE M8X70	HEXAGON HEAD SCREW M8X70
29	2-91680	DADO ES. M8	HEXAGON NUT M8
30	2-00128	DADO ES. M8	HEXAGON NUT M8
31	2-02006	VTCEI M8X25	HEXAGON SOCKET HEAD SCREW M8X25
32	2-02904	VTE M8X20	HEXAGON HEAD SCREW M8X20
33	5-105629	PATTINO COMPLETO	SLIDE ASSEMBLY
34	2-03577	VTE 1/2F M10X80	HEXAGON HEAD SCREW 1/2F M10X80
35	2-03633	RONDELLA D.10	WASHER D.10
36	2-02070	DADO ES.A. M10	AUTOLOCKING HEXAGON NUT M10
37	5-105630	PATTINO SUPERIORE + INSERTI	UPPER SLIDE
38	4-116471	INSERTO	INSERT
39	4-116476	INSERTO INTERMEDIO	INSERT
40	4-116469	SPESSORE 1 mm	SLIDE SHIM 1 mm
41	4-116470	SPESSORE 0,3 mm	SLIDE SHIM 0,3 mm
42	5-105621	PATTINO INFERIORE + INSERTI	LOWER SLIDE
43	2-01073	VTE 1/2F M10X40	HEXAGON HEAD SCREW 1/2F M10X40
44	436490	MOLLA COMPRESS. D.19X3,5X62	COMPRESSOR SPRING D.19X3,5X62
45	2-71734	SPINA D.6X18	PIN D.6X18
46	2-71733	SPINA D.10X20	PIN D.10X20
47	2-02008	VTCEI 1/2F M8X40	HEX. SOCKET HEAD SCREW 1/2F M8X40
48	421349	DADO ES.A. M8	AUTOLOCKING HEX. NUT M8
49	3006285	BIELLA	ROD
50	4-328676	CHIAVISTELLO	BOLT
51	5-107580	KIT LEVA CHIAVISTELLO	BOLT ASSEMBLY
52	2-02232	VTCEI M10X25	HEX. SOCKET HEAD SCREW M10X25

PANZITTA SALES & SERVICE
72 George Avenue
Wilkes-Barre, PA 18705
570-822-6720 800-822-6720
www.panzittasales.com

GRUPPO DISCO STALLONATORE DISCK BEAD GROUP

PANZITTA SALES & SERVICE
72 George Avenue
Wilkes-Barre, PA 18705
570-822-6720 800-822-6720
www.panzittasales.com

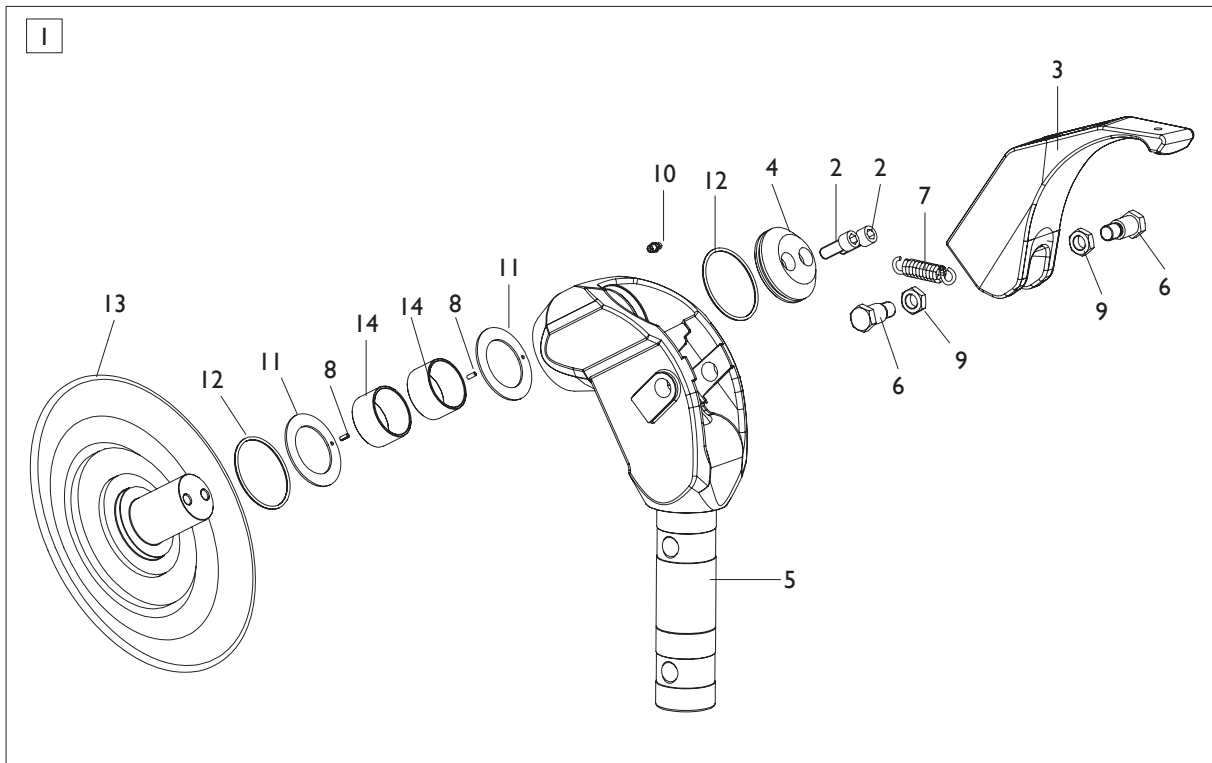

[TORNA AL COMPLESSIVO](#)
[RETURNS TO OVERALL](#)

Rif. Ref.	Codice Code	Descrizione	Description
1	5-300321	DISCO STALLONATORE COMPLETO	DISK ASSEMBLY
2	2-80101	VTCEI M12X30	HEXAGON SOCKET HEAD SCREW M12X30
3	237503	UNGHIA	TOOL
4	4-327271	RONDELLA D.12,5X78X22	WASHER D.12,5X78X22
5	4-327173	SUPPORTO UTENSILI	TOOL SUPPORT
6	336480	PERNO D.20X43	PIN D.20X43
7	3005977	MOLLA TRAZIONE	SPRING
8	2-03307	SPINA D.4X10	PIN D.4X10
9	2-03392	DADO ES.B. M16X1,5	LOWER HEXAGON NUT M16X1,5
10	81800800	INGRASSATORE M8	GREASER M8
11	4-329813	RALLA D.52X78X2	WASHER D.52X78X2
12	85600174	O-RING 174	O-RING 174
13	4-329814	DISCO STALLONATORE	DISK
14	3-01421	BOCCOLA D.50X30	BUSH D.50X30

PANZITTA SALES & SERVICE
72 George Avenue
Wilkes-Barre, PA 18705
570-822-6720 800-822-6720
www.panzittasales.com

GRUPPO BRACCIO MOBILE MOBILE ARM GROUP

PANZITTA SALES & SERVICE
72 George Avenue
Wilkes-Barre, PA 18705
570-822-6720 800-822-6720
www.panzittasales.com

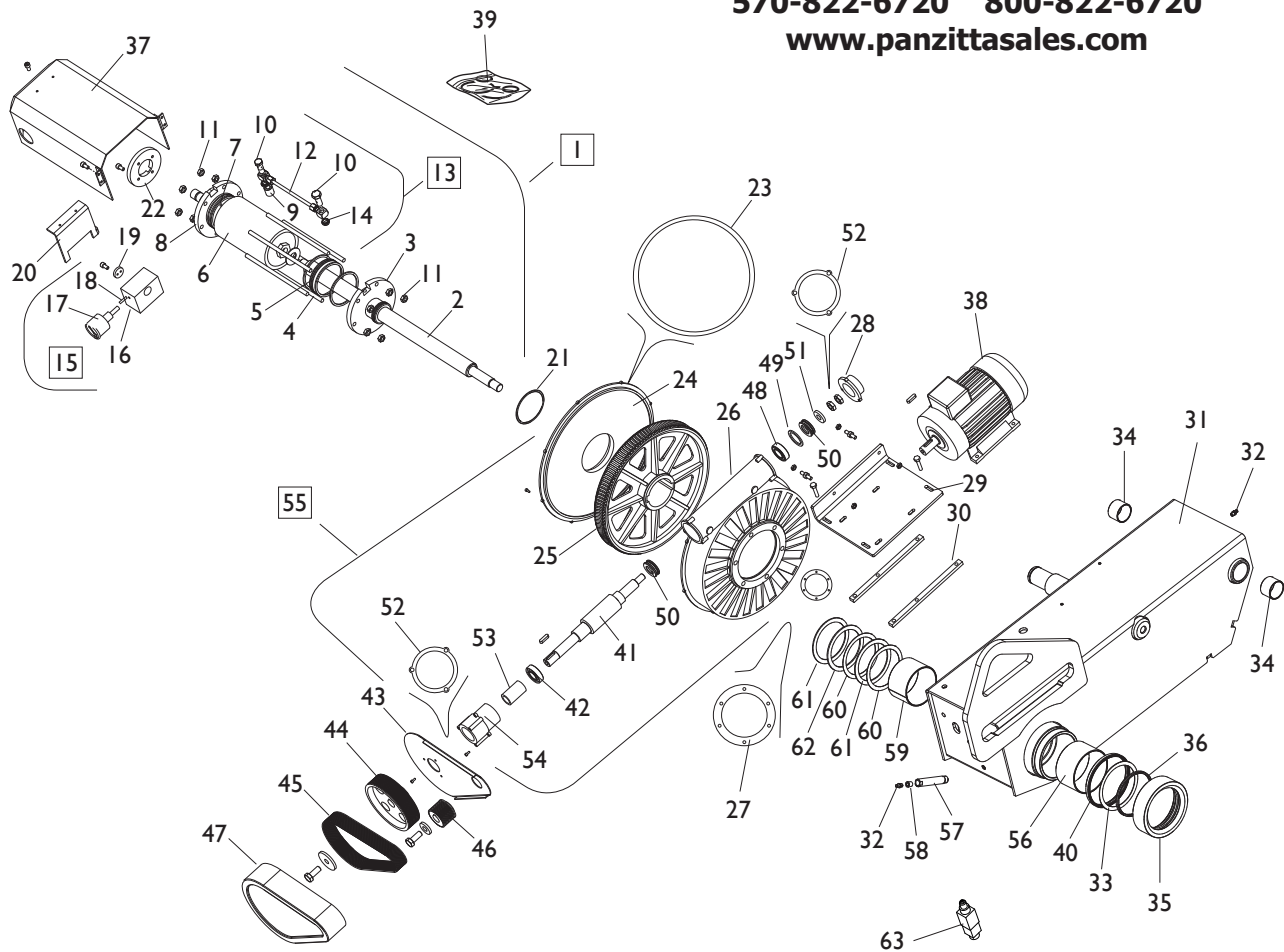

**TORNA AL COMPLESSIVO
RETURNS TO OVERALL**

Ref.	Code	Descrizione	Description
1	5-300417	CILINDRO AUTOCENTRANTE CPL.	CYLINDER ASSEMBLY
2	338599	STELO D.40X779,5	STEM D.40X779,5
3	239118	FLANGIA ANTERIORE	FRONT FLANGE
4	334204	TIRANTE M12	TIE ROD M12
5	338604	STANTUFFO	PISTON
6	338710	CAMICIA D.120X193,5	LINER D.120X193,5
7	440357	TAPPO	CAP
8	338777	FLANGIA POSTERIORE	REAR FLANGE
9	497751	PROLUNGA TUBO	PIPE EXTENTION
10	497438	VITE FORATA 1/8	SCREW 1/8

Ref.	Code	Descrizione	Description
11	2-91639	DADO ES. M12	HEXAGON NUT M12
12	497790	TUBO L.230mm	HOSE L.230mm
13	5-120584	KIT TUBO	HOSE KIT
14	497394	RONDELLA 1/8	WASHER 1/8
15	239596	DISTRIBUTORE COMPLETO	DISTRIBUTOR ASSEMBLY
16	440387	DISTRIBUTORE	DISTRIBUTOR
17	3-00491	MANOMETRO D.63 1/4 0-250 BAR/PSI	PRESSURE GAUGE D.63 1/4 0-250 BAR/PSI
18	459412	VALVOLA	VALVE
19	338778	RONDELLA FLANGIA POSTERIORE	FLANGE WASHER
20	339538	FERMO RACCORDO GIREVOLE	DISTRIBUTOR PLATE
21	453350	ANELLO DI TENUTA	RING
22	353343	FLANGIA BLOCCA RUOTA	WHEEL FLANGE
23	4-329053	GUARNIZIONE D.407X382X2	SEAL D.407X382X2
24	354213	COPERCHIO RIDUTTORE	GEAR COVER
25	341541	RUOTA D.378X43	WHEEL D.378X43
26	5-300181	KIT RINFORZO SCATOLA	BOX KIT
27	358951	GUARNIZIONE D.193X150,5X0,5	SEAL D.193X150,5X0,5
28	354875	FONDELLO ASSEVITE	FLANGE
29	355937	FLANGIA ATTACCO MOTORE	MOTOR PLATE
30	346852	PIATTO APPOGGIO MOTORE	BRACKET
31	5-121182	BRACCIO MOBILE	MOBILE ARM
32	81800800	INGRASSATORE M8	GREASER M8
33	354976	RONDELLA D.118X100X1	WASHER D.118X100X1
34	3-01163	BOCCOLA D.40X20	BUSH D.40X20
35	4-132584	ANELLO DISTANZIALE	SPACER
36	3-10158	GUARNIZIONE D.108X100X7	SEAL D.108X100X7
37	253346	CARTER CILINDRO	CYLINDER COVER
38	3-01224	MOTORE 2V 380V/3/50	2 SPEED MOTOR 380V/3/50
38	3-01602	MOTORE 2V 380V/3/60	2 SPPED MOTOR 380V/3/60
38	3-01223	MOTORE 2V 230V/3/50	2 SPEED MOTOR 230V/3/50
39	242012	KIT GUARNIZIONI CILINDRO AUTOC.	CYLINDER SEALS KIT
40	3-10159	GUARNIZIONE D.128X118X10	SEAL D.128X118X10
41	5-327657	KIT VITE SENZA FINE	SCREW KIT
42	2-02213	CUSCINETTO RADIALE D.25X62X17	BEARING D.25X62X17
43	353245	CARTER INFERIORE CINGHIA	LOWER COVER
44	355893	PULEGGIA 50 HZ	PULLEY 50 HZ
44	355896	PULEGGIA 60 HZ	PULLEY 60 HZ
45	3-00577	CINGHIA 50 HZ	BELT 50 HZ
45	3-00578	CINGHIA 60 HZ	BELT 60 HZ
46	355892	PULEGGIA 50/60 HZ	PULLEY 50/60 HZ
47	455891	CARTER CINGHIE MOTORE	BELT COVER
48	2-01034	CUSCINETTO RADIALE D.25X52X15	RADIAL BEARING D.25X52X15
49	317281	RONDELLA D.40X52X4	WASHER D.40X52X4
50	2-01035	CUSCINETTO ASSIALE D.25X47X15	AXIAL BEARING D.25X47X15
51	3015726	RONDELLA D.20,2X38X7	WASHER D.20,2X38X7
52	4-329212	GUARNIZIONE D.76X43X2	SEAL D.76X43X2
53	354881	BOCCOLA DISTANZIALE D.25,3X35X56	SPACER D.25,3X35X56
54	354876	FONDELLO ATTACCO CARTER	FLANGE
55	260124	KIT SCATOLA RIDUTTORE	GEAR BOX KIT
56	3-01238	BOCCOLA D.100X60	BUSH D.100X60
57	333052	TUBO MOZZO D.17,2	PIPE D17,2
58	354816	ATTACCO INGRASSATORE	GREASER SUPPORT
59	3-10157	BOCCOLA D.90X95X60	BUSH D.90X95X60
60	4-329223	RONDELLA D.90,5X109,5X0,2	WASHER D.90,5X109,5X0,2
61	4-132587	RONDELLA D.90,5X110X2	WASHER D.90,5X110X2
62	4-132588	RONDELLA D.90,5X110X2,5	WASHER D.90,5X110X2,5
63	422041	INTERRUTTORE FINECORSA	MICROSWITH

PANZITTA SALES & SERVICE
72 George Avenue
Wilkes-Barre, PA 18705
570-822-6720 800-822-6720
www.panzittasales.com

GRUPPO AUTOCENTRANTE TURNTABLE GROUP

PANZITTA SALES & SERVICE
72 George Avenue
Wilkes-Barre, PA 18705
570-822-6720 800-822-6720
www.panzittasales.com

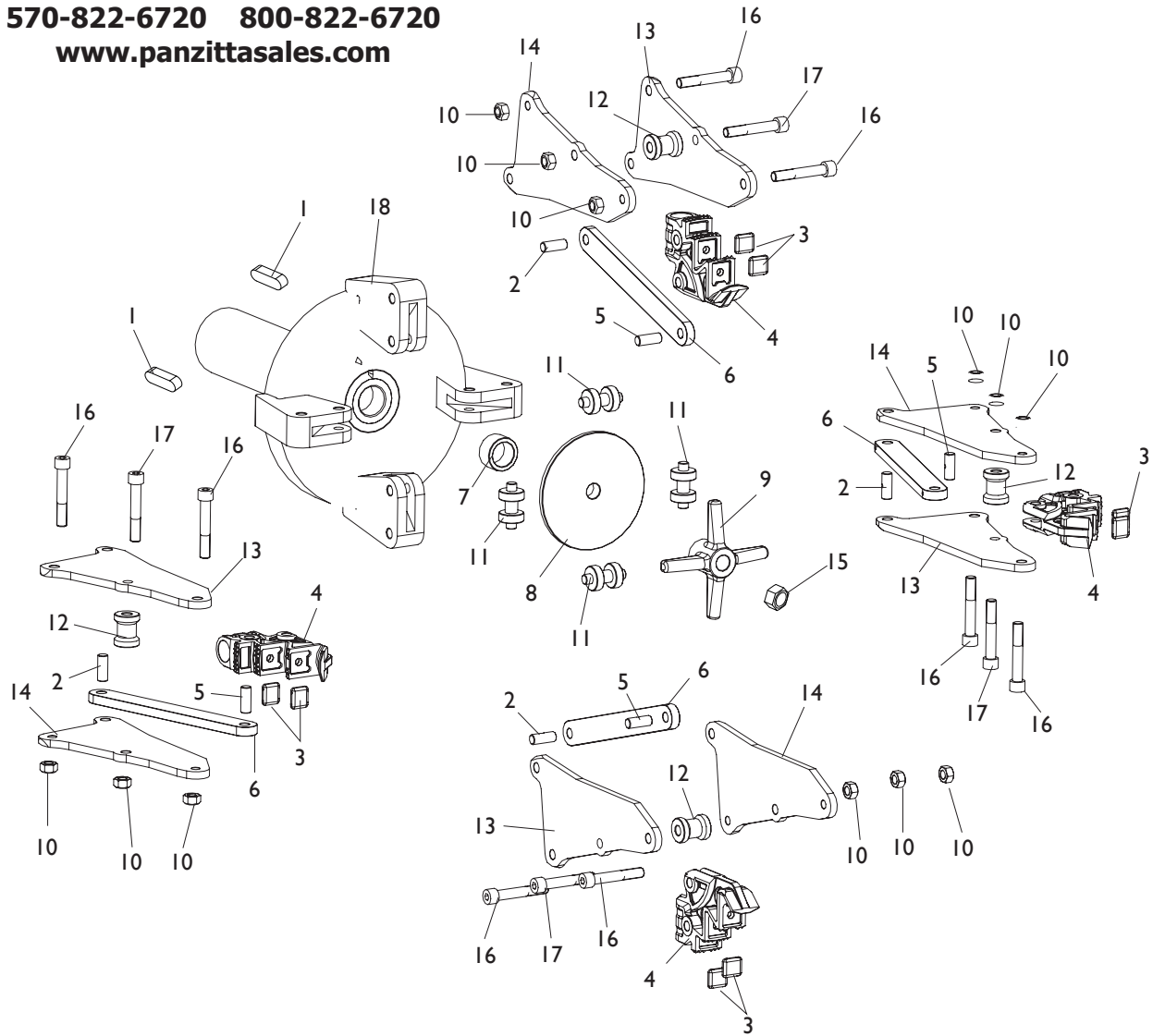

**TORNA AL COMPLESSIVO
RETURNS TO OVERALL**

Rif. Ref.	Codice Code	Descrizione	Description
1	2-01162	LINGUETTA D.20X12X60	KEY D.20X12X60
2	321564	SPINOTTO	PIN
3	435441	INSERTO D.30X34X6	INSERT D.30X34X6
4	4-326301	GRIFFA	SUPPORT
5	334164	SPINOTTO	PIN
6	334163	BIELLA	ROD
7	438592	BRONZINA D.40,25X55X30	BUSH D.40,25X55X30
8	338601	DISCO APERTURA AUTOCENTRANTE	DISK
9	338600	CROCE CHIUSURA AUTOCENTRANTE	LOCKING
10	422696	DADO ES.A. M16	AUTOLOCKING HEXAGON NUT M16
11	334170	RULLO SCANALATO	ROLLER
12	4-327973	DISTANZIALE D.40X50,5	SPACER D.40X50,5
13	4-327972	PIASTRA DX	RIGHT PLATE
14	4-327971	PIASTRA SX	LEFT PLATE
15	2-91674	DADO ES.A. M22X1,5	AUTOLOCKING HEXAGON NUT M22X1,5
16	4-326544	VITE SPECIALE M16X95	SPECIAL SCREW M16X95
17	4-326543	VTCCE M16X95	HEXAGON SOCKET HEAD SCREW M16X95
18	5-100600	AUTOCENTRANTE	TURNTABLE

PANZITTA SALES & SERVICE
72 George Avenue
Wilkes-Barre, PA 18705
570-822-6720 800-822-6720
www.panzittasales.com

GRUPPO PEDALIERA PEDAL GROUP

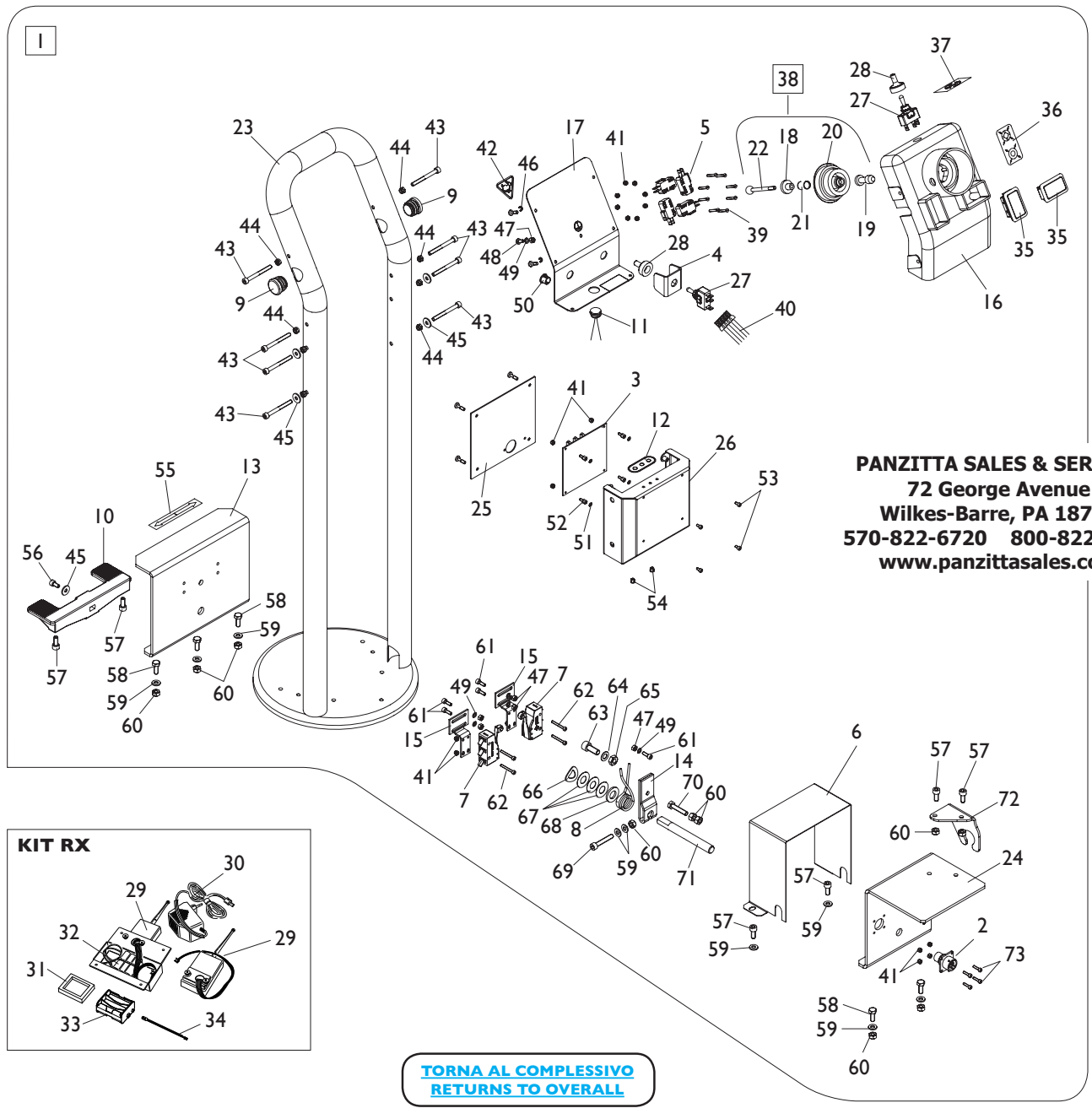

PANZITTA SALES & SERVICE
 72 George Avenue
 Wilkes-Barre, PA 18705
 570-822-6720 800-822-6720
www.panzittasales.com

Ref.	Code	Descrizione	Description
1	5-300287	PEDALIERA COMPLETA	PEDAL ASSEMBLY
2	4-327073	CAVO SERIALE TX	SERIAL CABLE TX
3	5-120628	SK RADIO 24 CANALI	RX P.C. BOARD
4	340747	PROTEZIONE DEVIATORE	SWITCH COVER
5	454405	MICROINTERRUTTORE	MICROSWITCH
6	355788	CARTER PEDALIERA	PEDAL COVER
7	3-03347	MICROINTERRUTTORE	MICROSWITCH
8	401270	MOLLA PEDALE D.18X2,8X14	PEDAL SPRING D.18X2,8X14
9	456036	TAPPO TONDO	CAP
10	330771 I	PEDALE NERO	BLACK PEDAL
11	4-327146	CAVO CARICA BATTERIE	BATTERY CABLE
12	4-327669	TARGHETTA LED	LABEL

Ref.	Code	Descrizione	Description
13	355787	PROTEZIONE PEDALE	PEDAL COVER
14	317491	LEVA COMANDI MICRO	COMMAND LEVER
15	355786	STAFFA PORTAMICRO	MICRO BRACKET
16	255791	SUPPORTO INTERRUZZORI	SUPPORT
17	355779	COPERCHIO SUPP. INTERRUZZORI	COVER
18	339002	GUIDA LEVA DI COMANDO	LEVER GUIDE
19	355781	POMOLO DI COMANDO	COMMAND KNOB
20	435301	CUFFIA PER MANIPOLATORE	COVER
21	439697	MOLLA D.10,2X38X0,9	SPRING D.10,2X38X0,9
22	339000	LEVA COMANDO	COMMAND LEVER
23	4-326251	PEDALIERA	BODY
24	4-327187	LAMIERA SUPPORTO GHIERA	PLATE
25	4-327176	COPERCHIO SUPPORTO INTERRUZZORI	COVER
26	4-327056	SCATOLA MODULO RADIO	RADIO BOX
27	3-03082	DEVIATORE 400V 15-10A	SWITCH 400V 15-10A
28	3-03085	PROTEZIONE IN GOMMA	RUBBER COVER
29	5-300221	RADIO MODEM	RADIO MODEM
30	4-330050	CARICA BATT. 100/240V 700ma	BATTERY CHARGER 100/240V 700ma
31	4-131822	PROTEZIONE BATTERIE	BATTERY COVER
32	4-110935	BLISTER 4 BATTERIE	BATTERY (4 PZ)
33	4-116398	PORTABATTERIE	BATTERY HOLDER
34	4-132001	CAVO BATTERIA	BATTERY CABLE
35	456186	TAPPO RETTANGOLARE 30X50X20	RECTANGULAR CAP 30X50X20
36	444848	TARGHETTA DEVIATORE AUTOC.	LABEL "TURNTABLE"
37	445834	TARGHETTA "TRASLAZIONI"	LABEL "TRANSLATION"
38	5-300506	KIT MANIPOLATORE	JOYSTIC ASSEMBLY
39	2-01238	VTSPE M3X20	SCREW M3X20
40	4-327230	CAVO 17X0,22mm L.1200mm	CABLE 17X0,22mm L.1200mm
41	2-01017	DADO ES.A. M3	AUTOLOCKING HEXAGON NUT M3
42	444883	TARGHETTA "2 VELOCITA'"	LABEL " 2 SPEED"
43	2-71755	VTCEI 1/2F M5X50	HEX. SOCKET HEAD SCREW 1/2F M5X50
44	2-71524	DADO ES.A. M5	AUTOLOCKING HEX. NUT M5
45	2-00713	RONDELLA D.5,5XX15X1,6	WASHER D.5,5X15X1,6
46	2-01287	SEEGER D.3,2	SEEGER D.3,2
47	2-00125	DADO ES. M4	HEXAGON NUT M4
48	2-00605	VTCIC M4X10	SCREW M4X10
49	2-71541	ROSETTA D.4	WASHER D.4
50	435957	TAPPO TONDO D.12,7 H8,7	CAP D.12,7 H8,7
51	2-71547	ROSETTA D.3	WASHER D.3
52	436072	DISTANZIALE M3	SPACER M3
53	2-00284	VTCEI M3X6	HEX. SOCKET HEAD SCREW M3X6
54	455345	TAPPO TONDO D.4,7 H.4,3	CAP D.4,7 H.4,3
55	421502	FRECCIA ROTAZIONE	LABEL
56	2-03546	VTCEI M5X10	HEX. SOCKET HEAD SCREW M5X10
57	2-00728	VTCEI M6X14	HEX. SOCKET HEAD SCREW M6X14
58	2-00361	VTE M6X16	HEXAGON HEAD SCREW M6X16
59	2-00211	RONDELLA D.6	WASHER D.6
60	2-00111	DADO ES. M6	HEXAGON NUT M6
61	2-00733	VTCEI M4X12	HEX. SOCKET HEAD SCREW M4X12
62	2-02907	VTCEI M3X25	HEX. SOCKET HEAD SCREW M3X25
63	2-00320	VTCEI M8X20	HEX. SOCKET HEAD SCREW M8X20
64	2-71542	ROSETTA D.8	WASHER D.8
65	2-00156	DADO ES. M8	HEXAGON NUT M8
66	2-02249	RONDELLA ELASTICA D.13X24	ELASTIC WASHER D.13X24
67	309197	RONDELLA D.12X25X0,6	WASHER D.12X25X0,6
68	2-00214	RONDELLA D.12	WASHER D.12
69	2-00909	VTCEI M6X35	HEX. SOCKET HEAD SCREW M6X35
70	2-00364	VTE M6X30	HEXAGON HEAD SCREW M6X30
71	4-330203	ASTA PEDALE D.12 L.208mm	PEDAL BAR D.12 L.208mm
72	4-131478	STAFFA CAVO COMANDI	COMMAND CABLE BRACKET
73	2-00287	VTCEI M3X12	HEX. SOCKET HEAD SCREW M3X12

PANZITTA SALES & SERVICE
72 George Avenue
Wilkes-Barre, PA 18705
570-822-6720 800-822-6720
www.panzittasales.com

GRUPPO CENTRALINA IDRAULICA HYDRAULIC POWER GROUP

PANZITTA SALES & SERVICE
72 George Avenue
Wilkes-Barre, PA 18705
570-822-6720 800-822-6720
www.panzittasales.com

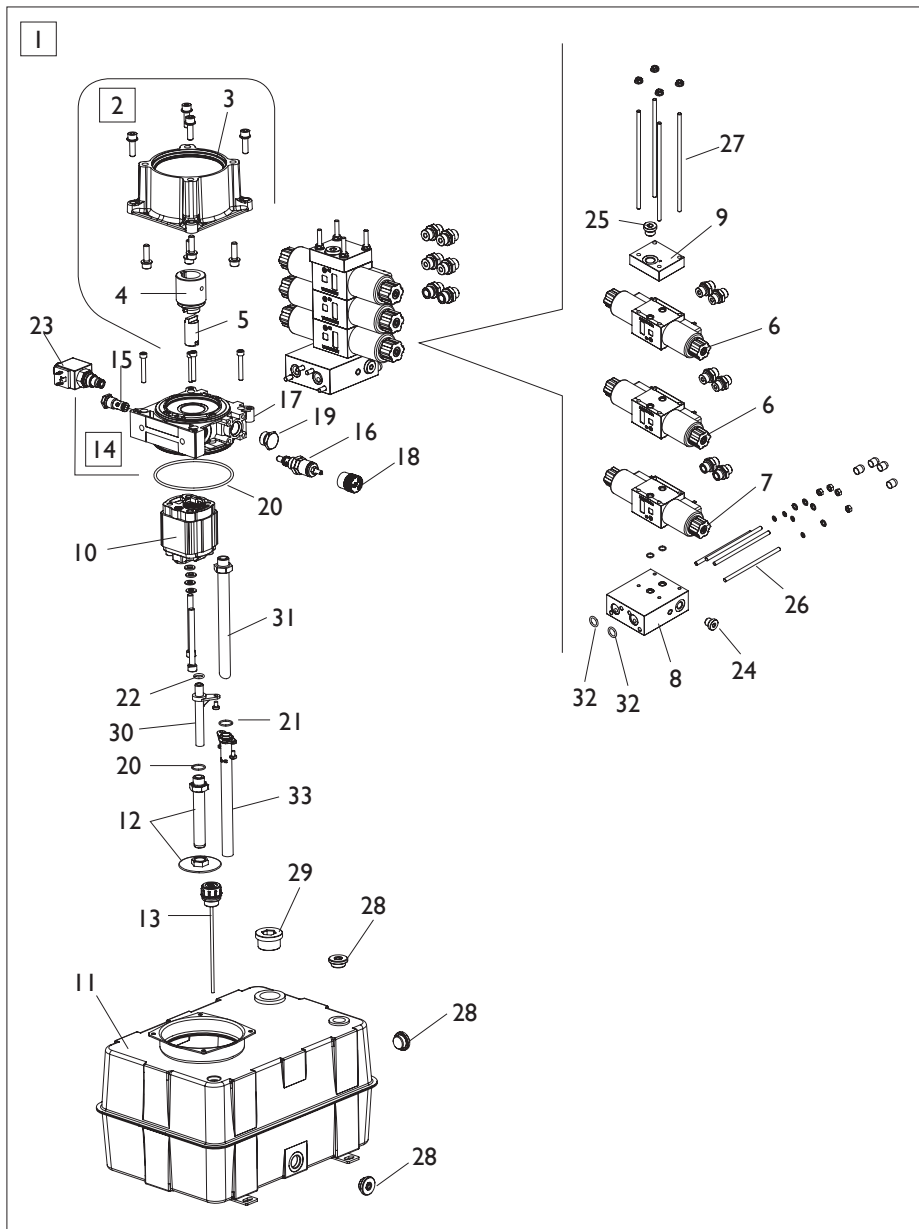
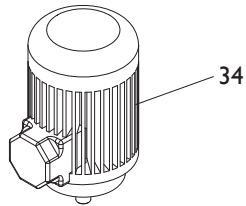

TORNA AL COMPLESSIVO
RETURNS TO OVERALL

Rif. Ref.	Codice Code	Descrizione	Description
1	5-300288	CENTRALINA IDRAULICA 50 HZ	HYDRAULIC POWER 50 HZ
1	5-300342	CENTRALINA IDRAULICA 60 HZ	HYDRAULIC POWER 60 HZ
2	4-131321	KIT DI TRASCINAMENTO	POWER PACK KIT
3	4-131329	FLANGIA MOTORE	MOTOR FLANGE
4	4-131333	GIUNTO MOTORE	MOTOR COUPLING
5	4-131332	GIUNTO POMPA	PUMP COUPLING
6	4-131313	ELETTRIVALVOLA	ELECTRIC VALVE
7	4-131312	ELETTRIVALVOLA	ELECTRIC VALVE
8	4-131320	BASE	BASE
9	4-131318	BASE	BASE
10	4-131315	POMPA I - 6,3 CC 50HZ	PUMP I - 6,3 CC 50HZ
10	4-131293	POMPA I - 4,8 CC 60HZ	PUMP I - 4,8 CC 60HZ
11	4-131326	SERBATOIO 14 LT	TANK 14 LT
12	5-107228	KIT ASPIRAZIONE 50HZ	SUCTION KIT 50HZ
12	5-107170	KIT ASPIRAZIONE 60HZ	SUCTION KIT 60HZ
13	4-131325	TAPPO CON ASTA LIVELLO	LEVEL CAP
14	4-131323	CORPO+RITEGNO	BODY WITH CHECK VALVE
15	4-131275	VALVOLA RITEGNO	CHECK VALVE
16	4-131274	VALVOLA DI MAX	RELIEF VALVE
17	4-131273	COLLETORE	BODY
18	4-131276	TAPPO VALVOLA DI MAX	RELIEF VALVE CAP
19	4-131277	TAPPO CORTO M20X1,5	SHORT CAP M20X1,5
20	4212271	O-RING D.110,72X3,53	O-RING D.110,72X3,53
21	436996	O-RING 2068/2	O-RING 2068/2
22	85603043	O-RING 3043/2	O-RING 3043/2
23	86990297	ELETTRIVALVOLA 24V	ELECTRIC VALVE 24V
24	4-131305	TAPPO CON OR 1/4	CAP 1/4 WITH O-RING
25	4-131317	TAPPO CON OR 3/8	CAP 3/8 WITH O-RING
26	4-131319	TIRANTE M6X130	TIE-ROD M6X130
27	4-131316	TIRANTE M6X199	TIE-ROD M6X199
28	4-131282	TAPPO CORTO 1/2 CON OR	SHORT CAP 1/2 WITH O-RING
29	4-131324	TAPPO CARICO OLIO	OIL CAP
30	4-131280	TUBO SCARICO VALVOLA DI MAX	RELIEF VALVE HOSE
31	4-131314	TUBO SCARICO L.177,5mm	HOSE L.177,5mm
32	85603056	O-RING 3056 D.13,94X2,62	O-RING 3056 D.13,94X2,62
33	4-131328	TUBO SCARICO L.186mm	HOSE L.186mm
34	444453	MOTORE 380V/3/50	MOTOR 380V/3/50
34	3-01601	MOTORE 380V/3/60	MOTOR 380V/3/60
34	445670	MOTORE 230V/3/50	MOTOR 230V/3/50

PANZITTA SALES & SERVICE
72 George Avenue
Wilkes-Barre, PA 18705
570-822-6720 800-822-6720
www.panzittasales.com

GRUPPO IMPIANTO ELETTRICO ELECTRIC SYSTEM GROUP

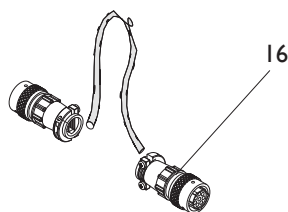
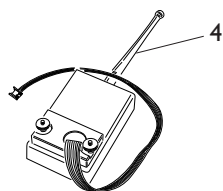
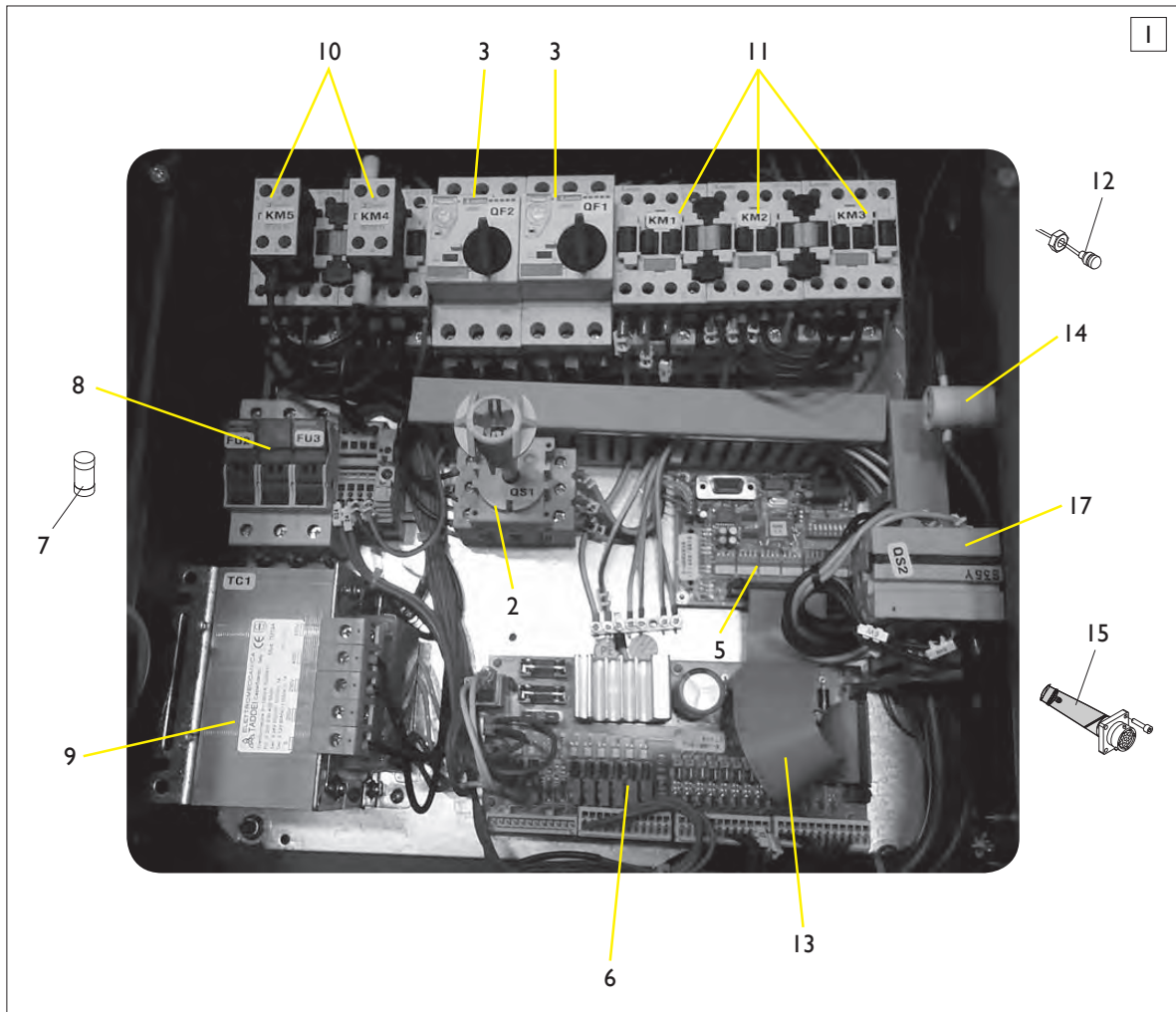

PANZITTA SALES & SERVICE
72 George Avenue
Wilkes-Barre, PA 18705
570-822-6720 800-822-6720
www.panzittasales.com

**TORNA AL COMPLESSIVO
 RETURNS TO OVERALL**

Rif. Ref.	Codice Code	Descrizione	Description
1	5-300236	IMPIANTO ELETTRICO CPL. 400V	ELECTRIC SYSTEM ASSEMBLY 400V
1	5-300237	IMPIANTO ELETTRICO CPL. 230V	ELECTRIC SYSTEM ASSEMBLY 230V
2	3-80140	INTERRUTTORE	SWITCH
3	3-80143	TERMICA 400V 6/10A	OVERLOAD CUTOUT 400V 6/10A
3	3-80147	TERMICA 230V 9/14A	OVERLOAD CUTOUT 400V 9/14A
4	5-300221	RADIO MODEM	RADIO MODEM
5	5-300283	SK HTCCB	P.C. BOARD HTCCB
6	5-300190	SK EPPB	P.C. BOARD EPPB
7	4-111957	FUSIBILE 10X38 RITARDATO 1A (400V)	FUSE 10X38 1A (400V)
7	84802502	FUSIBILE 10X38 2A (230V)	FUSE 10X38 2A (230V)
8	84990781	PROTAFUSIBILI 10X38 2P	FUSE HOLDER 10X38 2P
9	84100056	TRASFORMATORE	TRNASFORMER
10	5-107730	KIT 2 TELERUTTORI 12A 400V	KIT TWO REMOTE SWITCH 12A 400V
10	5-107663	KIT 2 TELERUTTORI 18A 230V	KIT TWO REMOTE SWITCH 18A 400V
11	5-491331	KIT 3 TELERUTTORI 12A 400V	KIT THREE REMOTE SWITCH 12A 400V
11	5-491332	KIT 3 TELERUTTORI 18A 230V	KIT THREE REMOTE SWITCH 18A 230V
12	4-327260	SPIA BIANCA	WHITE LAMP
13	4-327055	CAVO FLAT 30VIE L.20cm	FLAT CABLE 30-WAY L.20cm
14	218799	SPIA LUMINOSA	PILOT LAMP
15	4-327072	CAVO SERIALE RX	SERIAL CABLE RX
16	5-120607	CAVO COMANDI	COMMAND CABLE
17	3-80141	COMMUTATORE	COMMUTATOR

PANZITTA SALES & SERVICE
72 George Avenue
Wilkes-Barre, PA 18705
570-822-6720 800-822-6720
www.panzittasales.com

SCHEMA IDRAULICO HYDRAULIC DIAGRAM

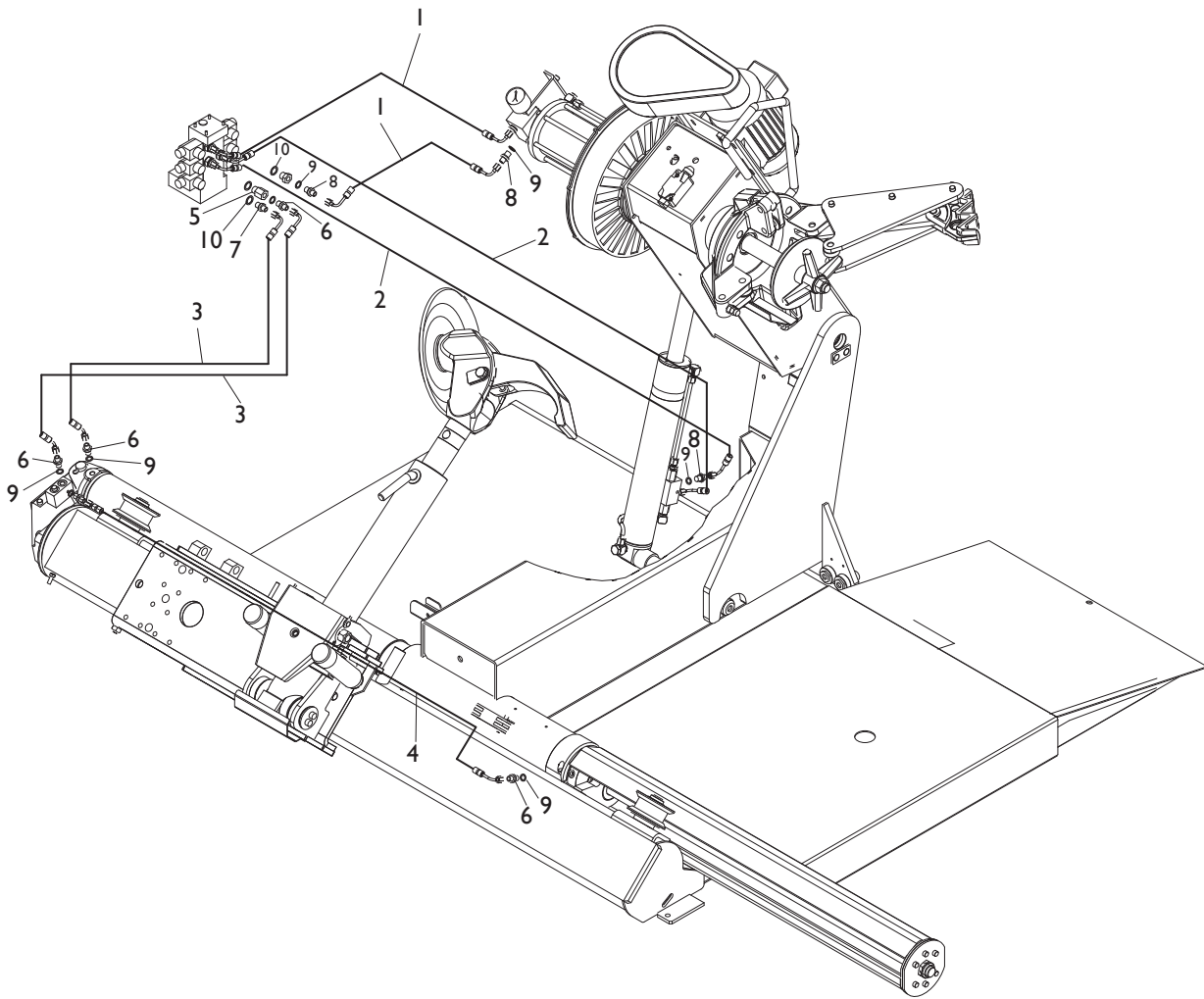

PANZITTA SALES & SERVICE
72 George Avenue
Wilkes-Barre, PA 18705
570-822-6720 800-822-6720
www.panzittasales.com

Rif. Ref.	Codice Code	Descrizione	Description
1	4-326821	TUBO L.2000mm	HOSE L.2000mm
2	4-326820	TUBO L. 650mm	HOSE L. 650mm
3	4-326815	TUBO L. 1750mm	HOSE L.1750mm
4	4-326816	TUBO L. 1675mm	HOSE L.1675mm
5	86200136	RACCORDO 3/8	FITTING 3/8
6	86200137	RACCORDO 1/4	FITTING 1/4
7	86200138	RACCORDO 3/8	FITTING 3/8
8	86200134	RACCORDO 1/4	FITTING 1/4
9	86500153	BONDED SEALS 1/4	BONDED SEALS 1/4
10	86500154	BONDED SEALS 3/8	BONDED SEALS 3/8

PANZITTA SALES & SERVICE
72 George Avenue
Wilkes-Barre, PA 18705
570-822-6720 800-822-6720
www.panzittasales.com