

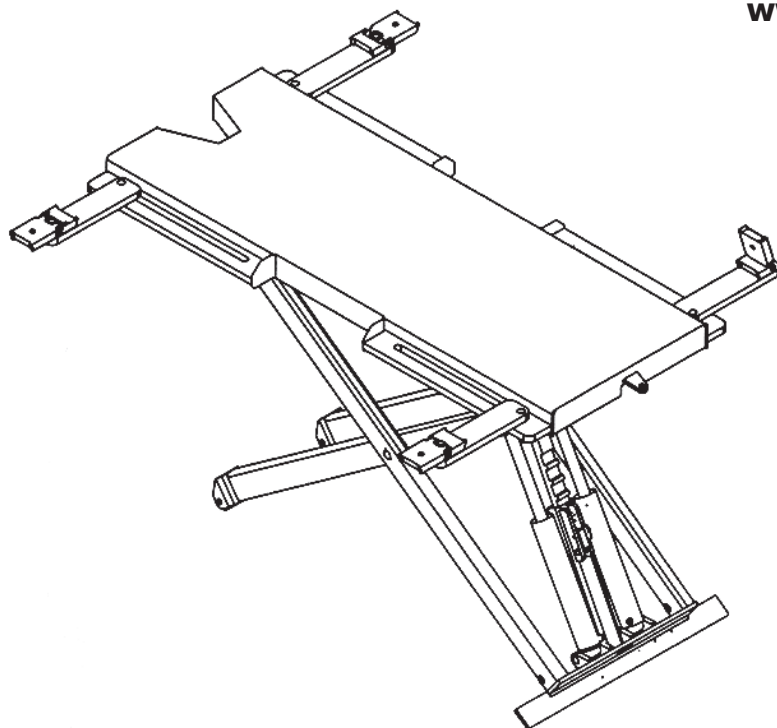

WHEELTRONIC LTD.

PANZITTA SALES & SERVICE
72 George Avenue
Wilkes-Barre, PA 18705
570-822-6720 800-822-6720
www.panzittasales.com



MIDRISE
MODEL
6500E/6500A
6,500 LB. CAPACITY

**READ and SAVE THIS
INSTRUCTION MANUAL**



WHEELTRONIC LTD.

PANZITTA SALES & SERVICE
72 George Avenue
Wilkes-Barre, PA 18705
570-822-6720 800-822-6720
www.panzittasales.com

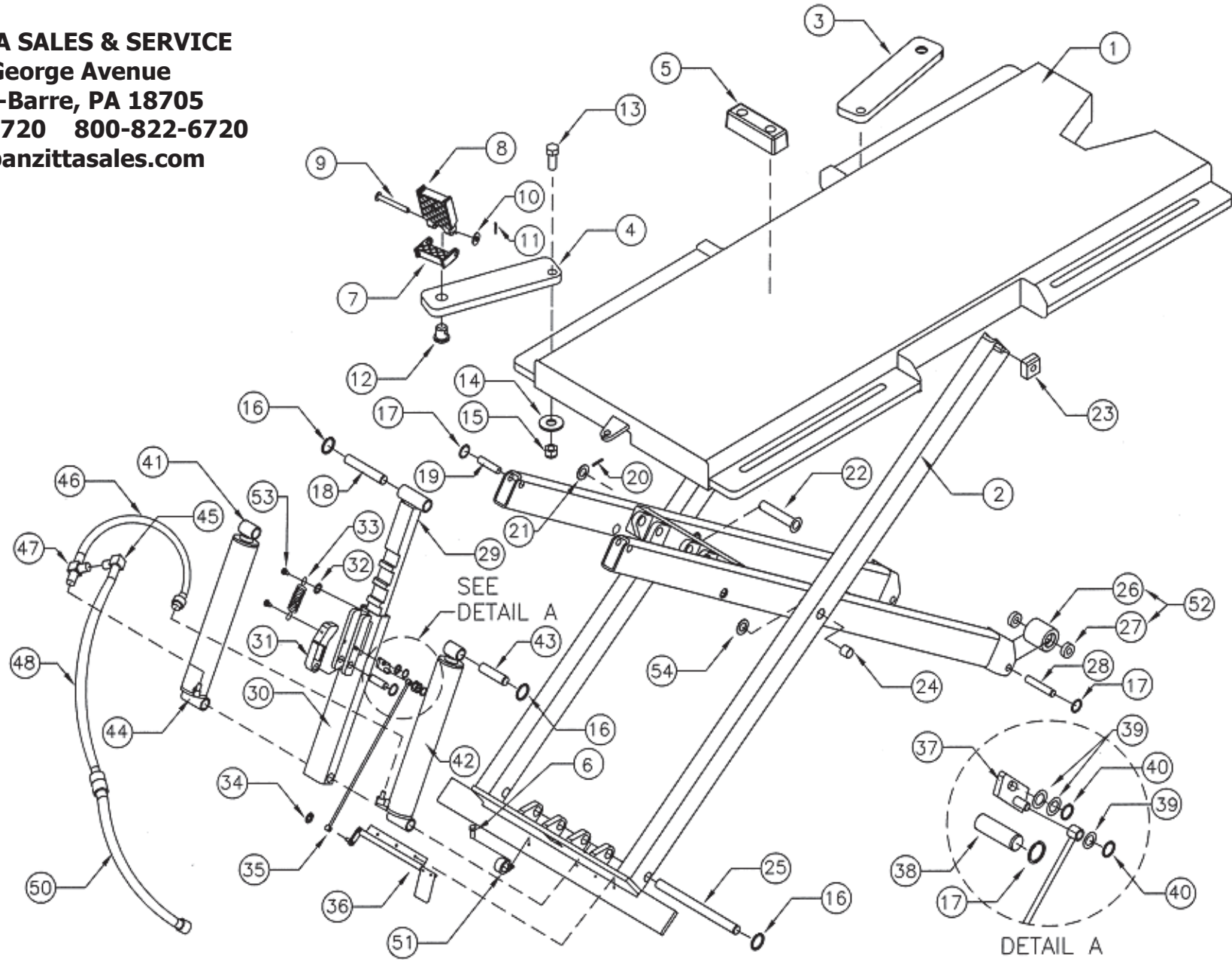

10.1 MIDRISE MAIN FRAME ASSEMBLY

10.2 MIDRISE MAIN FRAME ASSEMBLY - PARTS LIST

ITEM NO.	QTY.	DESCRIPTION	PART NO.
1	1	DECK ASSEMBLY	4-0944
2	1	SCISSOR ASSEMBLY	4-0943
3	2	ARM (RIGHT FRONT / LEFT REAR)	2-1809
4	2	ARM (LEFT FRONT / RIGHT REAR)	2-1808
5	4	RUBBER BLOCK	6-1074
6	4	SELF TAPPING SCREW #12 X ½" LG.	6-1134
7	4	LOW ADAPTER	3-0583
8	4	HIGH ADAPTER	3-0582
9	4	CENTER PIN	1-1099
10	4	FLAT WASHER ½" I.D.	6-0063
11	4	COTTER PIN 1/8" X 1 ½" LG.	6-0267
12	4	ADAPTER PIN	1-1091
13	4	ARM BOLT	1-1076
14	4	FLAT WASHER 1" I.D.	6-1106
15	4	LOCK NUT 1"- 8 UNC	1-1385
16	8	EXTERNAL SNAP RING 1"	6-0581*
17	10	EXTERNAL SNAP RING ¾"	6-2445*
18	1	SAFETY UPPER PIN	1-2342
19	2	HINGE PIN	1-2336
20	2	SPRING PIN 3/16" X 1 ¼" LG.	6-0749
21	2	KEEPER WASHER	1-0725
22	2	SCISSOR PIN	1-2373
23	2	GLIDE BLOCK	1-2335
24	8	OILITE BUSHING 1" I.D.	6-1620
25	1	LOWER CYLINDER MOUNTING PIN	1-2343
26	2	ROLLER	1-0807
27	4	BEARING	6-0751
28	2	ROLLER PIN	1-2338
29	1	SAFETY RACK	2-1821*
30	1	SAFETY OUTER	3-0844*
31	1	SAFETY LOCK	1-2371*
32	1	FLAT WASHER #10 I.D.	6-0816*
33	1	SPRING	1-1115*
34	1	RETAINER 5/16"	6-2470*
35	1	PUSHROD	2-1822*
36	1	SAFETY PEDAL ASSEMBLY	2-1823
37	1	SAFETY RESET	1-2370*
38	1	SAFETY LOCK PIN	1-2337*
39	3	FLAT WASHER 5/16"	6-0295*
40	2	EXTERNAL SNAP RING 5/16"	6-2449*
41	1	HYDRAULIC CYLINDER (P.S.)	3-0839
42	1	HYDRAULIC CYLINDER (D.S.)	3-0838
43	2	UPPER CYLINDER MOUNTING PIN	1-2340
44	2	FLOW CONTROL 90° ELBOW	6-1638
45	1	90° SWIVEL ELBOW	6-2467
46	1	HYDRAULIC HOSE 13"	1-2368
47	1	SWIVEL TEE	6-2466

ITEM NO.	QTY.	DESCRIPTION	PART NO.
48	1	HYDRAULIC HOSE 19" LG.	1-0858
49	1	3/8" NPT-F 90 DEGREE HYDRAULIC STEEL FITTING	6-0006
50	1	HYDRAULIC HOSE 12'	2-0602
51	1	TUBE CLAMP 1/2"	6-0536
52	2	ROLLER ASSEMBLY KIT (W/ ROLLER BEARINGS)	0-0191
53	2	SELF TAPPING SCREW #10 X 3/8" LG.	6-0169*
54	4	THRUST WASHER	6-0807

NOTE: ITEMS MARKED WITH (*) ARE PART OF *SAFETY ASSEMBLY KIT # 0-0900.*

PANZITTA SALES & SERVICE
72 George Avenue
Wilkes-Barre, PA 18705
570-822-6720 800-822-6720
www.panzittasales.com

10.3 HYDRAULIC CYLINDER ASSEMBLY

PANZITTA SALES & SERVICE
72 George Avenue
Wilkes-Barre, PA 18705
570-822-6720 800-822-6720
www.panzittasales.com

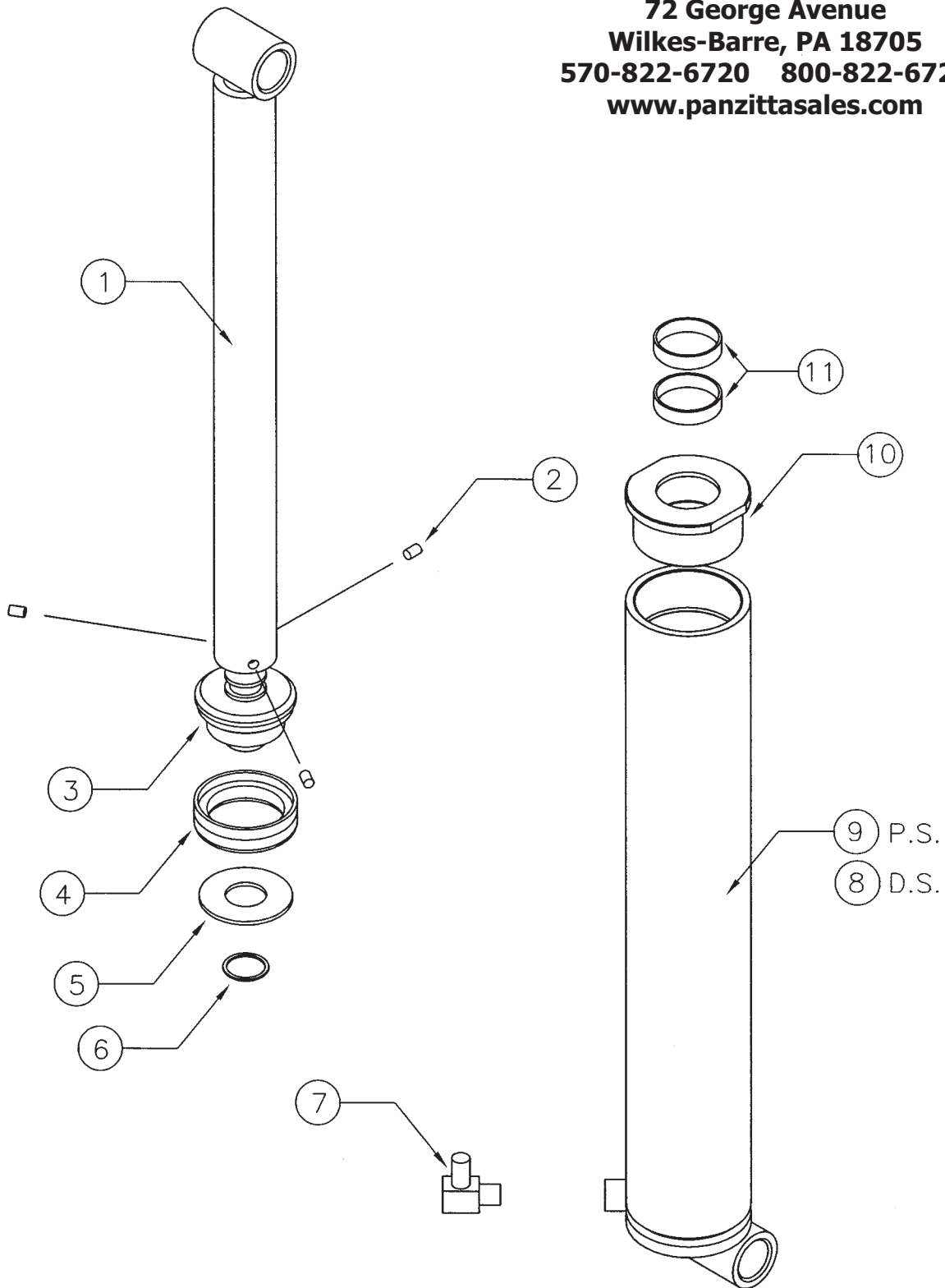

10.4 HYDRAULIC CYLINDER ASSEMBLY - PARTS LIST

ITEM NO.	QTY.	DESCRIPTION	PART NO.
1	1	PISTON TUBE WELDMENT	2-1827
2	3	SET SCREW	6-0580
3	1	PISTON	2-1806
4	1	PISTON SEAL KIT	6-2915*
5	1	KEEPER WASHER	1-1148
6	1	EXTERNAL SNAP RING	6-0581*
7	1	FLOW CONTROL 90° ELBOW	6-1638
8	1	CYLINDER TUBE (D.S.)	2-1828
9	1	CYLINDER TUBE (P.S.)	2-1829
10	1	GLAND	1-2345
11	2	WEAR RING	6-2093

NOTE: PART NUMBERS MARKED WITH AN ASTERIX (*)
ARE CONTAINED IN REPAIR KIT NUMBER 0-1287 (1 CYL.) AND
0-1288 (2 CYL.)

PANZITTA SALES & SERVICE
72 George Avenue
Wilkes-Barre, PA 18705
570-822-6720 800-822-6720
www.panzittasales.com

10.5 POWER UNIT TOW CART

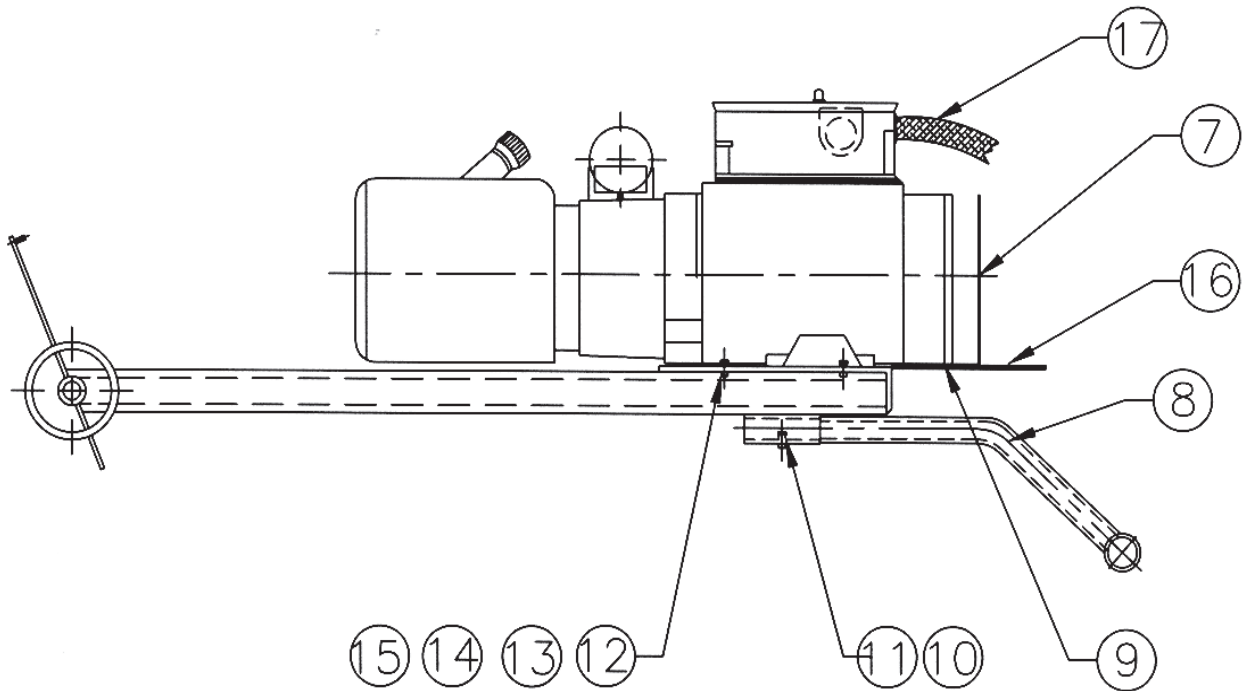
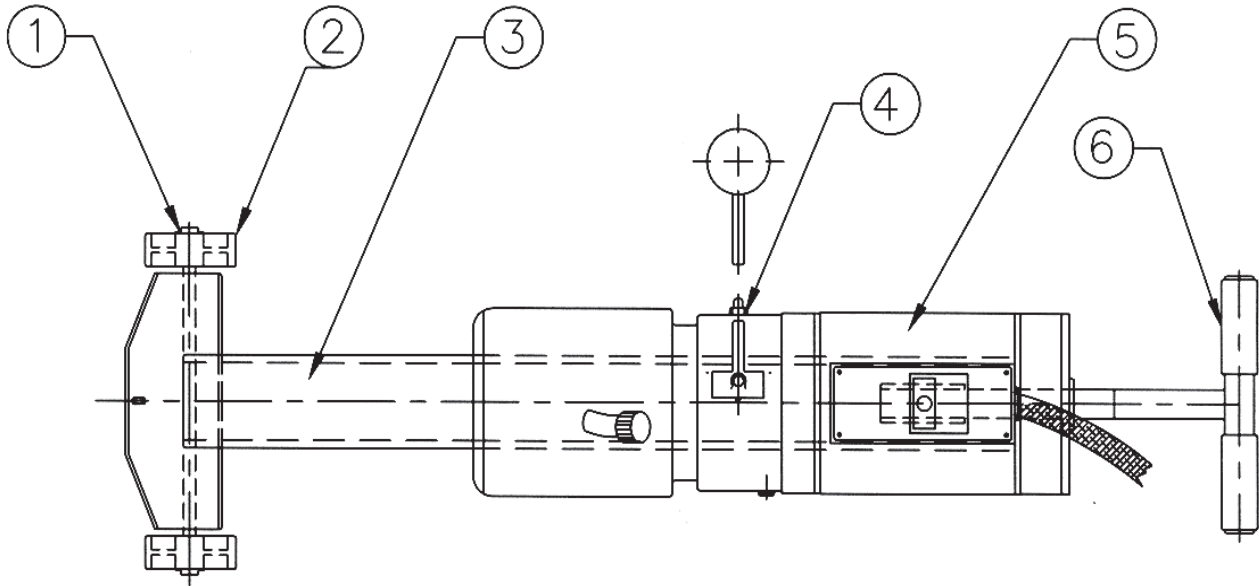

PANZITTA SALES & SERVICE
72 George Avenue
Wilkes-Barre, PA 18705
570-822-6720 800-822-6720
www.panzittasales.com

10.6 POWER UNIT TOW CART - PARTS LIST

ITEM NO.	QTY.	DESCRIPTION	PART NO.
1	2	HUB CAP NUT	6-1833
2	2	WHEEL	6-0753
3	1	STAND (INCLUDING WHEELS AND HUB CAP NUTS)	4-0207-01
4	1	90° ELBOW	6-1093
5	1	POWER UNIT 115/230V 1PH 60HZ 1 HP	6-2249
6	2	GRIP HANDLE	6-0758
7	1	DECAL "OPERATING INSTRUCTIONS"	6-2469
8	1	"T" HANDLE (INCLUDING GRIPS AND HARDWARE)	3-0408-01
9	1	BRACKET	1-0853
10	1	HEX BOLT 1/4"-20UNC X 3/4" LG.	6-0178
11	1	LOCKWASHER 1/4" I.D.	6-0056
12	4	HEX BOLT 5/16"-18UNC X 3/4" LG.	6-0423
13	4	LOCKWASHER 5/16" I.D.	6-0674
14	4	FLAT WASHER 5/16" I.D.	6-0295
15	4	HEX NUT 5/16"-18UNC	6-0294
16	1	ALI PLACARD	6-0990
17	1	PLUG	6-1711
*	1	COMPLETE TOWCART W/ ELECTRIC POWER UNIT	4-0955

-SEE NEXT PAGE FOR THE POWER UNIT ASSEMBLY

PANZITTA SALES & SERVICE
72 George Avenue
Wilkes-Barre, PA 18705
570-822-6720 800-822-6720
www.panzittasales.com

10.7 POWER UNIT: #6-2249 (AB-1425) 115-230V/1PH/60HZ

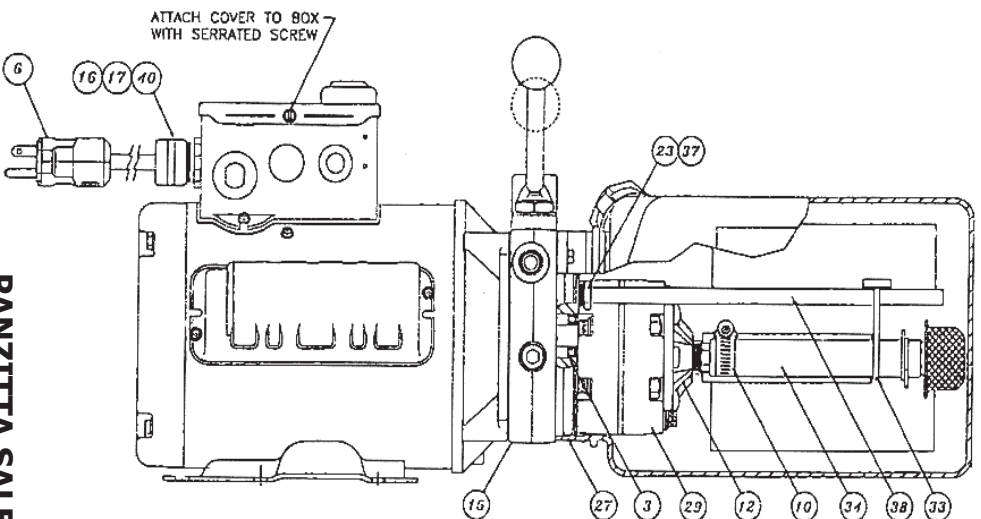
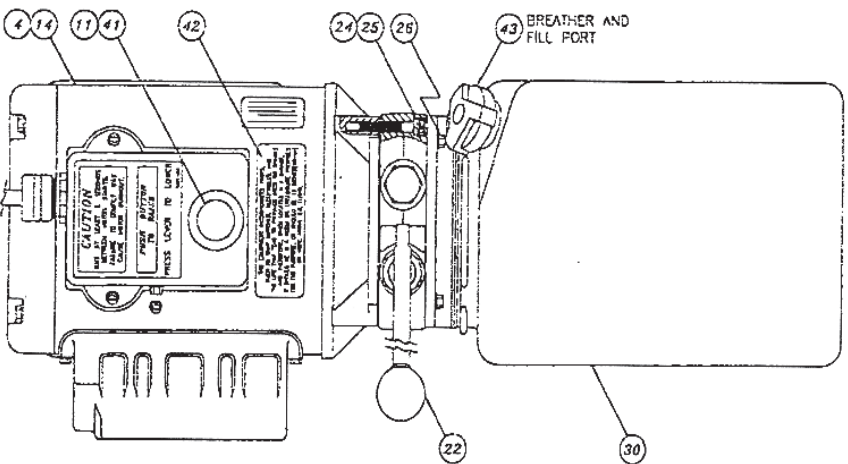
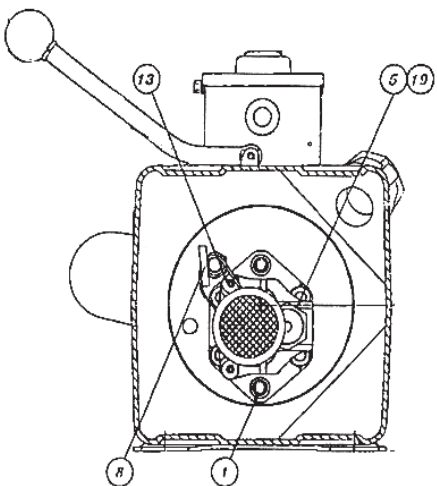
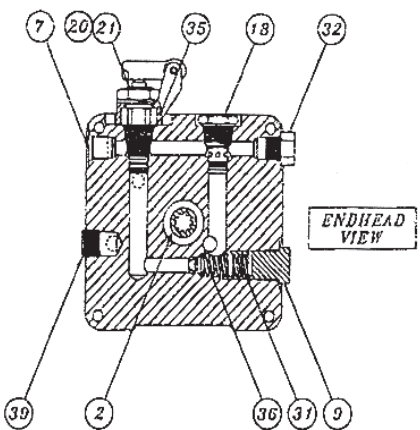

PANZITTA SALES & SERVICE
 72 George Avenue
 Wilkes-Barre, PA 18705
 570-822-6720 800-822-6720
 www.panzittasales.com

10.8 POWER UNIT PARTS LIST: #6-2249 (AB-1425) 115-230V/1PH/60Hz

ITEM PART #	QTY.	DESCRIPTION	
1	2	BOLT 5/16"-24 x 2 3/4" TORX G8	6-2298
2	1	COUPLING SAE 9T-20/40 1.260"	6-0774
3	1	SEAL SHAFT 0.500" x 1.00" x 0.25"	6-2158
4	1	MOTOR AC PSC #613000 115/230 1 HP 1PH BLK	6-2299
5	1	WASHER 0.338" x 0.625" x 0.060" STEEL	6-2159
6	1	CORDSET 16/3 SJO 8FT 115V PLUG	6-2300
7	1	PACKAGE PLUG 9/16" SAE	6-2301
8	1	PLUMBING MAGNET	6-2162
9	1	RELIEF VALVE CAP ASSEMBLY	6-1089
10	1	PLUMBING CLAMP HOSE ADJ INLET	6-2166
11	2	ELECTRIC STAKON NUT	6-2302
12	1	COVER ASS'Y SUCTION	6-2165
13	2	SCREW TAPTITE M6x1.0 12MM TORX	6-2164
14	1	NAMEPLATE, SERIAL	
15	1	ENDHEAD UNIVERSAL AUTOHOIST	6-2155
16	1	ELECTRIC CORD GRIP 3/4" NPT	6-2303
17	1	ELECTRIC PIPENUT 3/4"	6-2304
18	1	VALVE CARTRIDGE CHECK	6-1087
19	1	VALVE LOAD DELAY	6-2305
20	1	NUT 3/4"-16 x 1" HEX x 0.250 STEEL	6-2167
21	1	WASHER 3/4" INT. TOOTH LOCK	6-2168
22	1	BRACKET HANDLE ASS'Y REL BLACK	6-0776
23	1	COMPRESSION TUBE NUT	6-2153
24	4	BOLT M6 x 1.0 35MM SOC HD	6-2169
25	4	WASHER 1/4" LOCK HI-COLLAR	6-2170
26	4	BOLT #12-24 x .50 HEX WSHRHD	6-1091
27	1	O-RING 2-348 BUNA	6-0875
28	1	COVER ASSY SUCTION	6-2165
29	1	PUMP ASS'Y 0.8 SHORT SPLINE	6-2306
30	1	TANK PLASTIC 6.7 CT 11.0" BLACK	6-2307
31	1	SPRING 0.480" x 0.063" x 0.42" COMP	6-2151
32	1	PLUMBING PLUG 5/16" SAE	6-2157
33	1	CABLE TIE 8" LONG WHITE	6-1846
34	1	PLUMBING ASS'Y INLET 6.61 (3)	6-2308
35	1	VALVE CARTRIDGE RELEASE MANUAL	6-0880
36	1	RELIEF ASSEMBLY FIXED 260 BAR	6-1326
37	1	COMPRESSION TUBE SLEEVE	6-2154
38	1	RETURN HOSE 3/8" OD x 10.0"	6-2310
39	1	PLUMBING PLUG 3/8"NPT	6-2161
40	2	ELECTRIC REDUCER WASHER	6-2311
41	1	WIRING ASSEMBLY AC 1PH FENNER	6-2156
42	1	LABEL INSTALLATION AUTOHOIST	6-2136
43	1	BREATHER CAP & BLADDER	6-1376

PANZITTA SALES & SERVICE
72 George Avenue
Wilkes-Barre, PA 18705
570-822-6720 800-822-6720
www.panzittasales.com

10.9 AIR POWER UNIT TOW CART

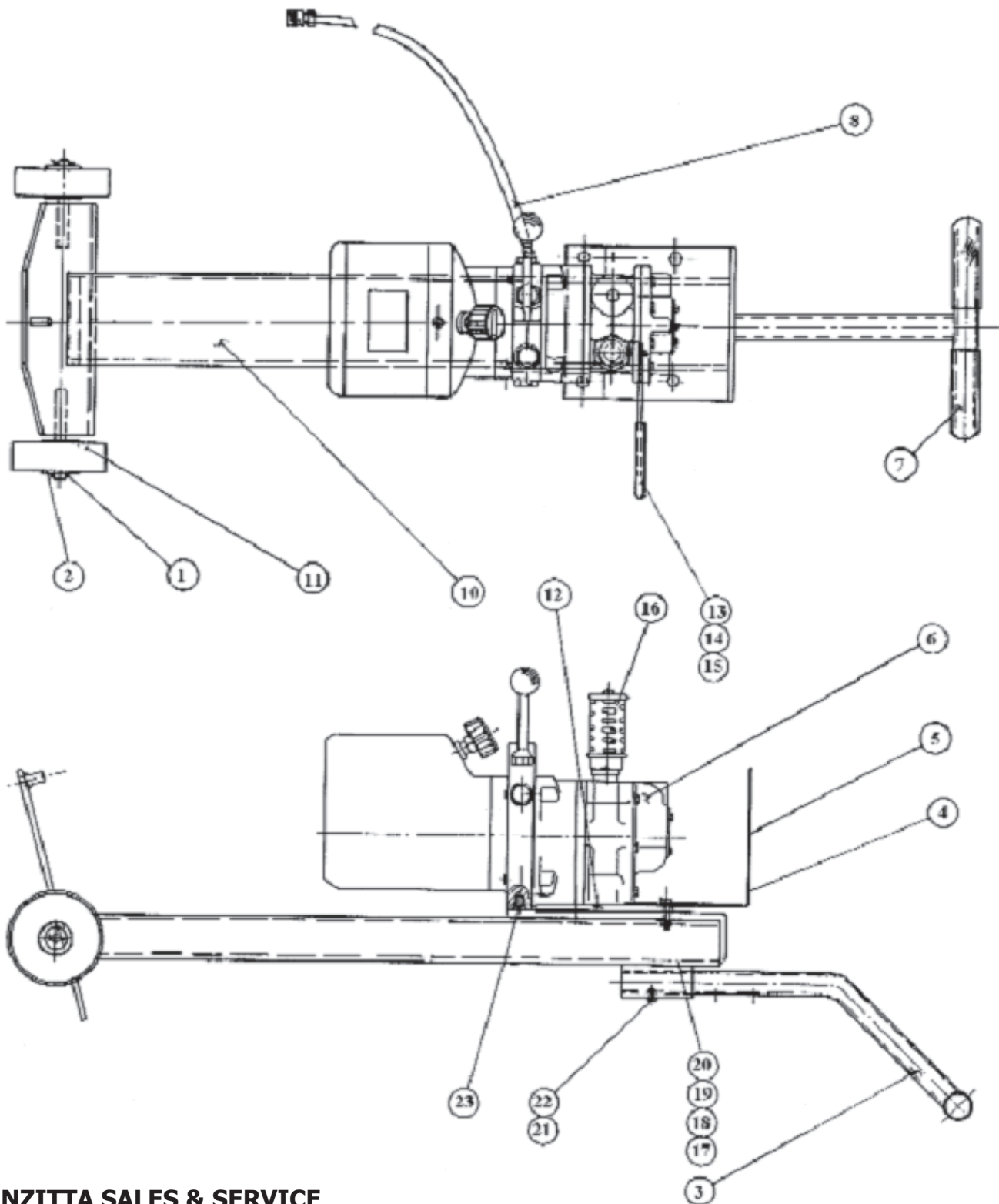

PANZITTA SALES & SERVICE
72 George Avenue
Wilkes-Barre, PA 18705
570-822-6720 800-822-6720
www.panzittasales.com

10.10 AIR POWER UNIT TOW CART - PARTS LIST

ITEM NO.	QTY	DESCRIPTION	PART NO.
1	2	1 /2" PUSHNUT	6-1833
3	1	"T" HANDLE (INCLUDING GRIPS AND HARDWARE)	3-0408-01
4	1	BRACKET	1-0853
5	1	DECAL "OPERATING INSTRUCTIONS"	6-2469
6	1	AIR HYDRAULIC PUMP "AC-10TC UTILIZING VA-4S VANE AIR MOTOR"	6-0919
7	2	GRIP HANDLE	6-0758
8	1	HYDRAULIC HOSE – 12FT.	2-0602
10	1	STAND (INCLUDING WHEELS AND HUB CAP NUTS)	4-0207-01
11	2	WHEEL	6-0753
12	1	MOTOR MOUNT BRACKET	2-0739
13	1	BALL VALVE	6-0940
14	1	3/8" STEEL NIPPLE	6-0953
15	1	REDUCER 3/4" M PIPE/ 3/8" F PIPE	6-0285
16	1	EXHAUST MUFFLER	6-0958
17	4	LOCKWASHER 5/16" I.D.	6-0674
18	4	HEX BOLT 5/16"-18UNC X 3/4" LG.	6-0423
19	4	FLAT WASHER 5/16" I.D.	6-0295
20	2	HEX. NUT 5/16"-18UNC	6-0294
21	1	HEX BOLT 1/4"-20UNC X 3/4" LG.	6-0178
22	1	LOCKWASHER 1/4" I.D.	6-0056
23	1	FLAT HD. SCREW - 3/8" - 16 x 1/2" LG.	6-0955
*	1	COMPLETE TOWCART W/ AIR POWER UNIT	4-0958

PANZITTA SALES & SERVICE
72 George Avenue
Wilkes-Barre, PA 18705
570-822-6720 800-822-6720
www.panzittasales.com