

PANZITTA SALES & SERVICE
72 George Avenue
Wilkes-Barre, PA 18705
570-822-6720 800-822-6720
www.panzittasales.com

MANITOWOC LIFTS

PARTS LIST

CFF-90

FREE FLOOR ASYMMETRIC LIFT

F-52A40D0500 (208/230V., 1PH.)

F-52A50D0500 (200/230V., 3PH.)

LIFT CAPACITY 9,000 LBS.
2,250 LBS. PER SWING ARM

When ordering replacement parts, always mention lift model number and serial number.

Item No.	No. Req.	Part No.	Description
1	1	R18230-62	Column Weldment (Drive)
2	1	R18230-03	Base Angle (Drive)
3	1	R18230-64	Tie Bar
4	1	R18230-65	Cable Sheave
5	1	R18230-184	Pin
6	2	R18230-122	Cotter Pin
7	6	R18230-170	Anchor Bolt
8	6	R18230-152	1/2-13 x 1-3/4" Bolt
9	4	R18230-153	1/2-13 Hex Nut
10	6	R18230-155	1/2 Dia. Lock Washer
11	8	R18230-157	1/2 Dia. Flat Washer
12	4	R18230-160	5/8-11 x 1-3/4" Bolt
13	4	R18230-162	5/8-11 Hex Nut
14	4	R18230-164	5/8" Dia. Lock Washer
15	4	R18230-166	5/8" Dia. Flat Washer
16	2	R18230-08	Column Shim Pack
17	1	R18230-09	7" Bumper
18	1	R18230-92	12" Bumper

PANZITTA SALES & SERVICE
 72 George Avenue
 Wilkes-Barre, PA 18705
 570-822-6720 800-822-6720
 www.panzittasales.com

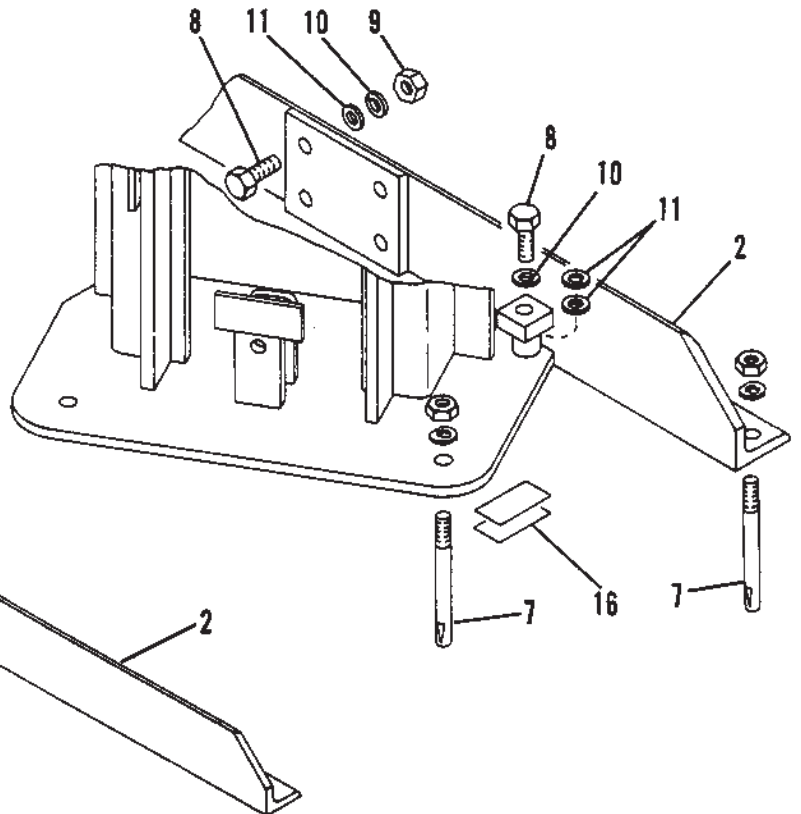
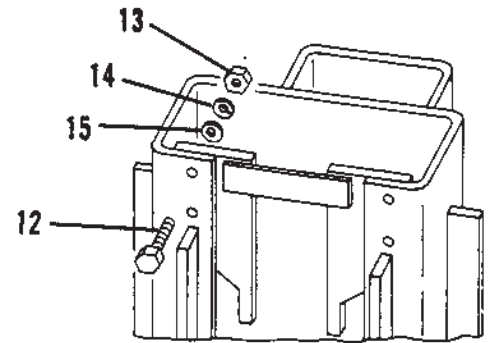
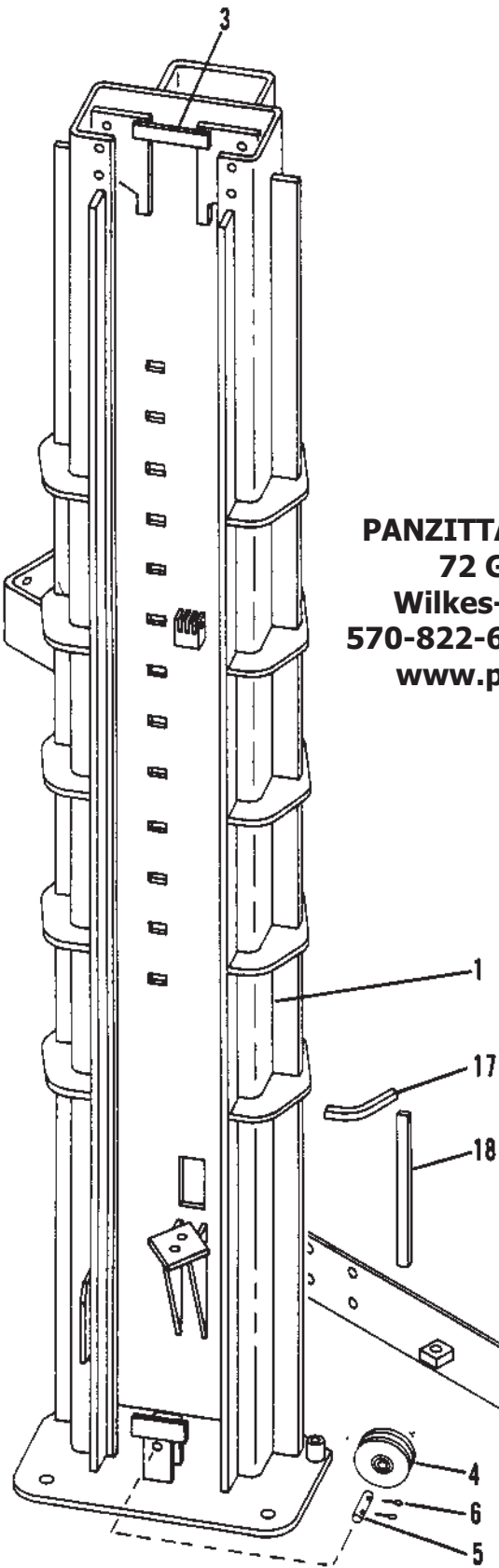

COLUMN (DRIVE SIDE)

When ordering replacement parts, always mention lift model number and serial number.

Item No.	No. Req.	Part No.	Description
1	1	R18230-63	Column Weldment (Slave)
2	1	R18230-04	Base Angle (Slave)
3	1	R18230-64	Tie Bar
4	1	R18230-65	Cable Sheave
5	1	R18230-184	Pin
6	2	R18230-122	Cotter Pin
7	6	R18230-170	Anchor Bolt
8	6	R18230-152	1/2-13 x 1-3/4" Bolt
9	4	R18230-153	1/2-13 Hex Nut
10	6	R18230-155	1/2 Dia. Lock Washer
11	8	R18230-157	1/2 Dia. Flat Washer
12	4	R18230-160	5/8-11 x 1-3/4" Bolt
13	4	R18230-162	5/8-11 Hex Nut
14	4	R18230-164	5/8" Dia. Lock Washer
15	4	R18230-166	5/8" Dia. Flat Washer
16	2	R18230-08	Column Shim Pack
17	1	R18230-09	7" Bumper
18	1	R18230-92	12" Bumper

PANZITTA SALES & SERVICE

72 George Avenue
 Wilkes-Barre, PA 18705
 570-822-6720 800-822-6720
 www.panzittasales.com

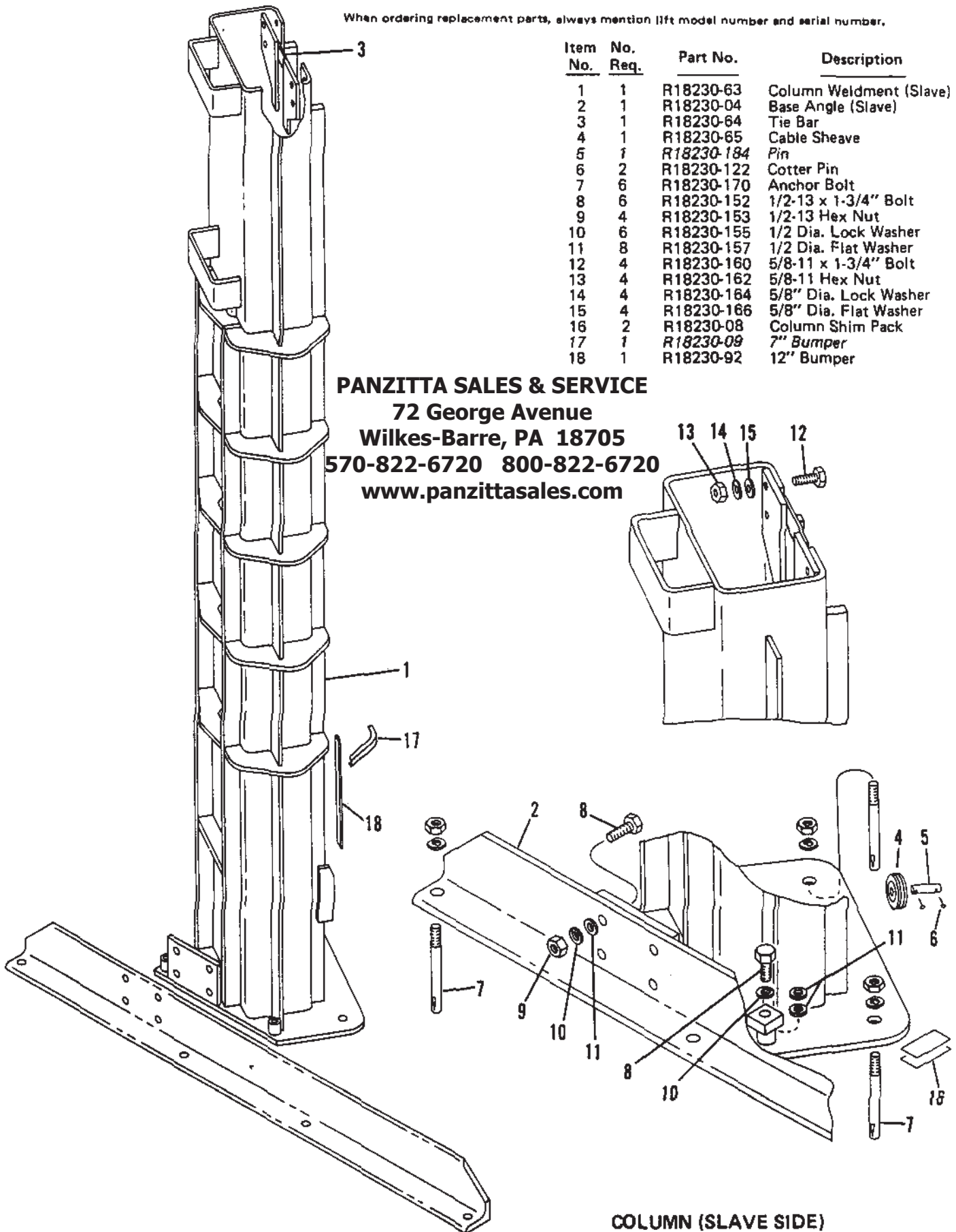

COLUMN (SLAVE SIDE)

When ordering replacement parts, always mention lift model number and serial number.

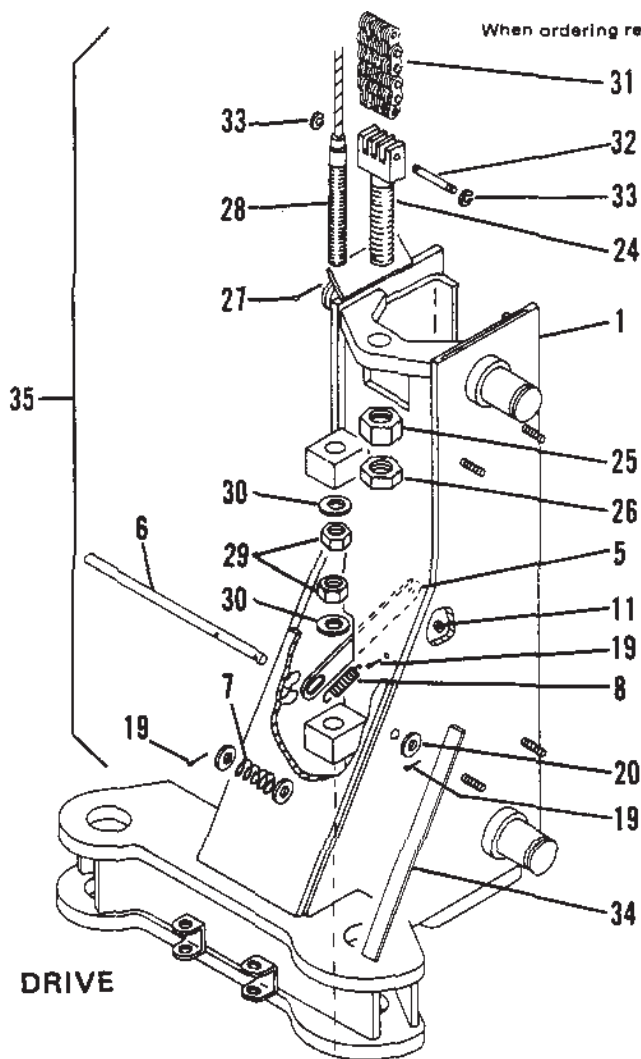

DRIVE

Item No.	No. Req.	Part No.	Description
1	1	R18230-252	Carriage Weldment (Drive)
2	1	R18230-253	Carriage Weldment (Slave)
3	1	R18230-13	Counterweight
4	1	R18230-70	Safety Dog
5	1	R18230-15	Link
6	1	R18230-16	Lever
7	1	R18230-17	Compression Spring
8	1	R18230-18	Extension Spring
9	1	R18230-127	Roll Pin 3/16" Dia. x 1
10	1	R18230-120	Cotter Pin 1/16" Dia. x 1/2
11	1	R18230-131	No. 6 SAE Flat Washer
12	4	R18230-19	Roller (Main)
13	8	R18230-20	Thrust Washer (Large)
14	4	R18230-21	Retaining Ring
15	4	R18230-22	Roller (Side)
16	4	R18230-23	Bracket
17	8	R18230-24	Thrust Washer (Small)
18	4	R18230-25	Pin (Side Roller)
19	11	R18230-122	Cotter Pin 1/8" Dia. x 1
20	3	R18230-148	3/8" Dia. Flat Washer
21	8	R18230-146	3/8-16 Hex Nut
22	8	R18230-147	3/8" Dia. Lock Washer
23	2	R18230-26	Shim Pack (Carriage)
24	1	R18230-72	Chain Retainer
25	1	R18230-175	7/8-9 Hex Nut
26	1	R18230-176	7/8-9 Hex Jam Nut
27	1	R18230-121	Cotter Pin 1/8" Dia. x 1-1/4
28	1	R18230-73	Wire Rope
29	2	R18230-168	3/4-10 Nylon Insert Nut
30	2	R18230-169	3/4" Dia. SAE Flat Washer
31	1	R18230-74	Leaf Chain
32	2	R18230-75	Chain Pin
33	4	R18230-31	Retaining Ring
34	1	R18230-32	Rubber Bumper
35	1	R18230-254	Drive Carriage Complete - Includes Items 1, 3 thru 23 and 34
36	1	R18230-255	Slave Carriage Complete - Includes Items 2 thru 23 and 34

NOTE!

Items No. 3 thru No. 34 are the quantity required per carriage, for entire lift, double quantities.

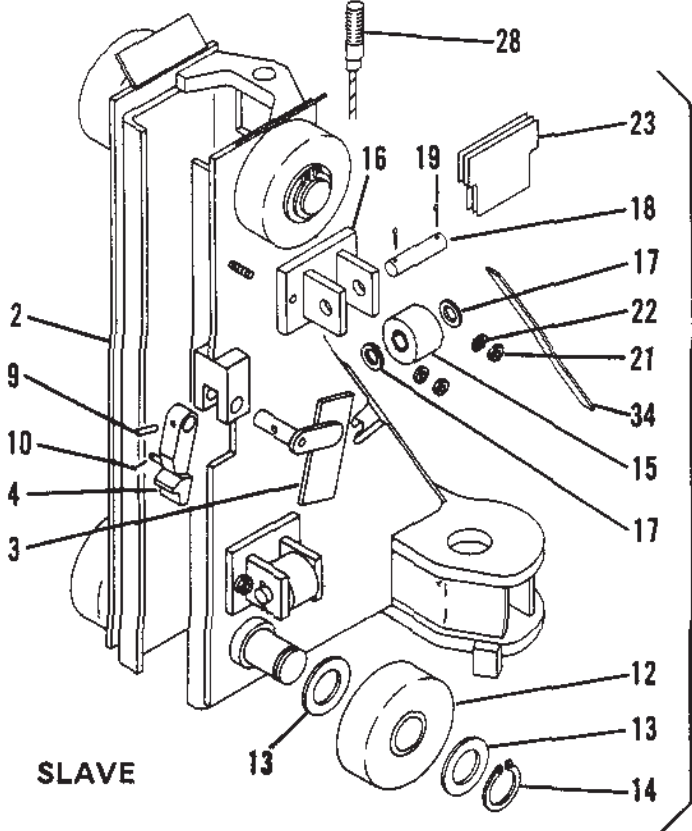

SLAVE

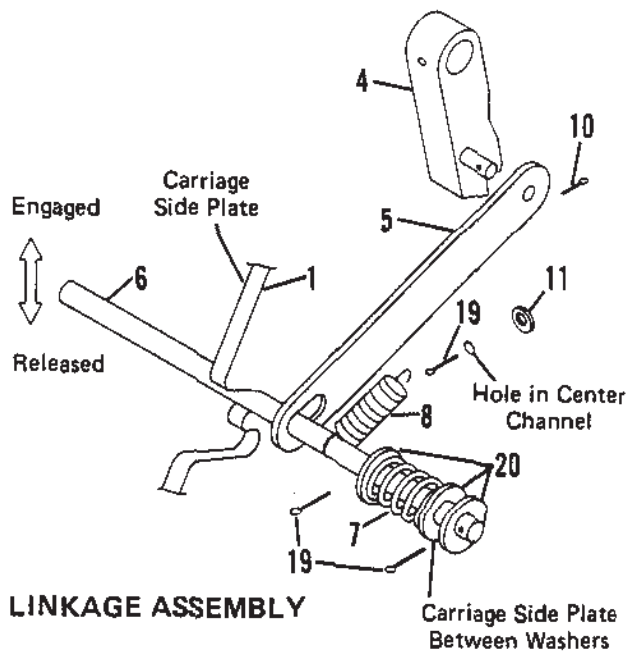

LINKAGE ASSEMBLY

CARRIAGE (EITHER SIDE)

When ordering replacement parts, always mention lift model number and serial number.

Item No.	No. Req.	Part No.	Description
1	1	R18230-78	Hose 1/4" x 370"
2	1	R18230-79	Hose 1/4" x 31"
3	1	R18230-80	Hose 3/8" x 21"
4	3	R18230-90	90° Fitting
5	1	R18230-91	Tee Fitting
6	6	R18230-81	Hose & Wire Clip

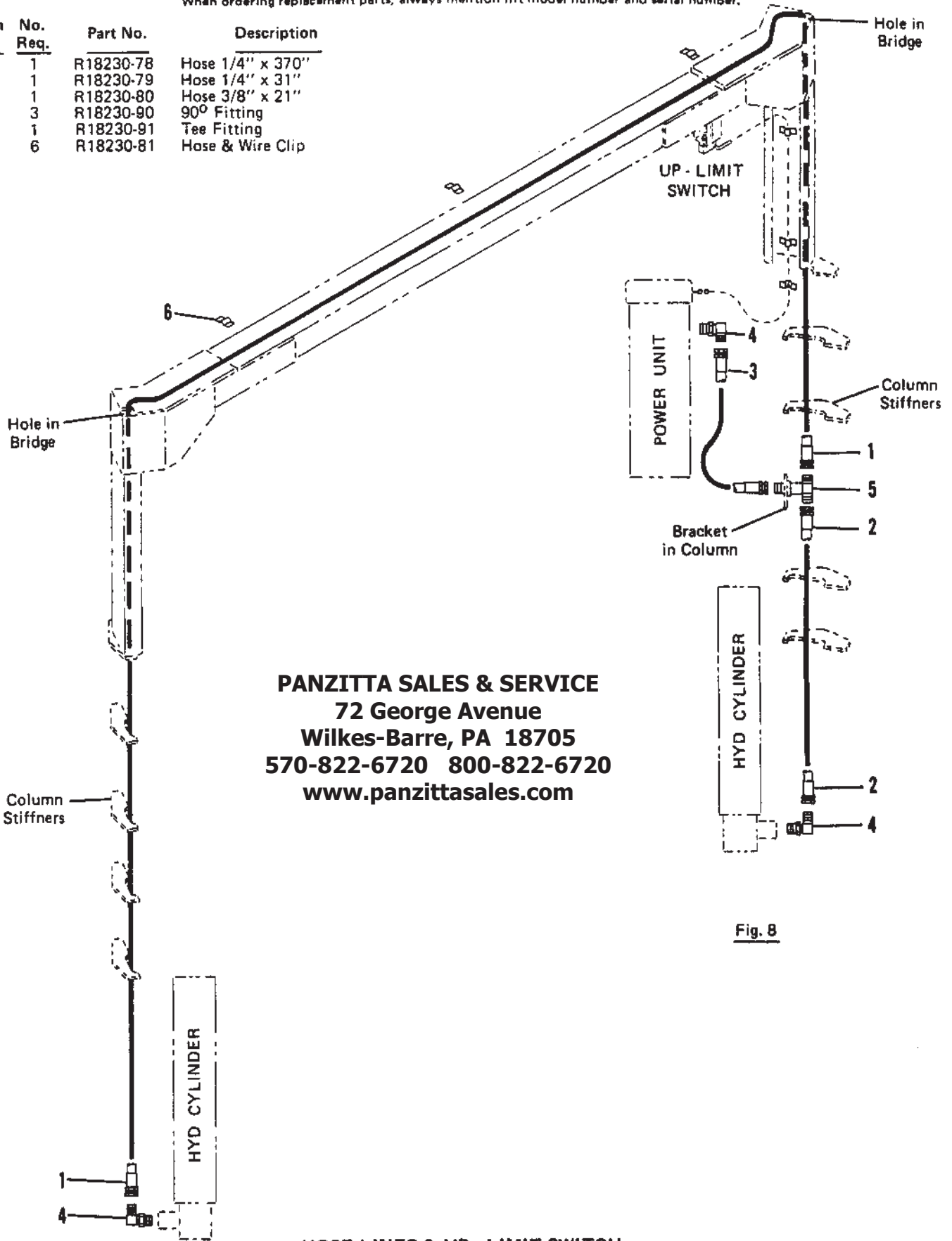

PANZITTA SALES & SERVICE
 72 George Avenue
 Wilkes-Barre, PA 18705
 570-822-6720 800-822-6720
 www.panzittasales.com

Fig. 8

HOSE LINES & UP - LIMIT SWITCH

When ordering replacement parts, always mention lift model number and serial number.

Item No.	No. Req.	Part No.	Description
1	1	R18230-82	Bridge Support (Drive)
2	1	R18230-83	Bridge Support (Slave)
3	4	R18230-65	Cable Sheave
4	4	R18230-184	Pin
5	8	R18230-122	Cotter Pin
6	8	R18230-151	1/2-13 x 1" Bolt
7	8	R18230-154	1/2-13 Hex Nut
8	8	R18230-156	1/2" Dia. Lock Washer
9	8	R18230-158	1/2" Dia. Flat Washer

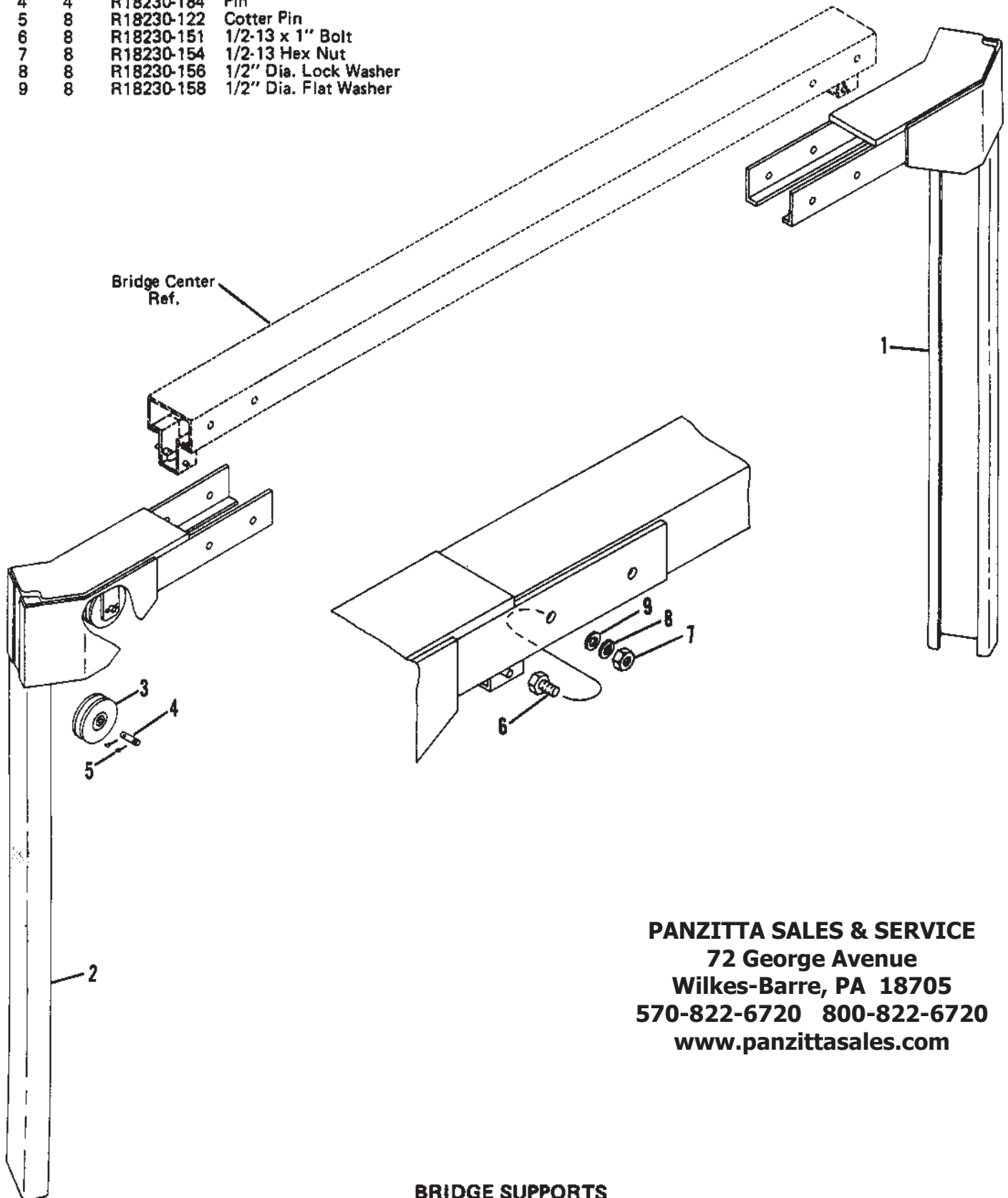

PANZITTA SALES & SERVICE
 72 George Avenue
 Wilkes-Barre, PA 18705
 570-822-6720 800-822-6720
 www.panzittasales.com

BRIDGE SUPPORTS

When ordering replacement parts, always mention lift model number and serial number.

PANZITTA SALES & SERVICE
72 George Avenue
Wilkes-Barre, PA 18705
570-822-6720 800-822-6720
www.panzittasales.com

Item No.	No. Req.	Part No.	Description
1	1	R18230-35	Center Bridge
2	1	R18230-36	Tube (Up-Limit)
3	1	R18230-37	Actuator
4	2	R18230-38	Pin
5	4	R18230-39	Spacer
6	4	R18230-120	Cotter Pin 1/16 Dia. x 1/2
7	2	R18230-137	1/4" Dia. SAE Flat Washer
8	1	R18230-41	Cushion
9	1	R18230-42	Switch

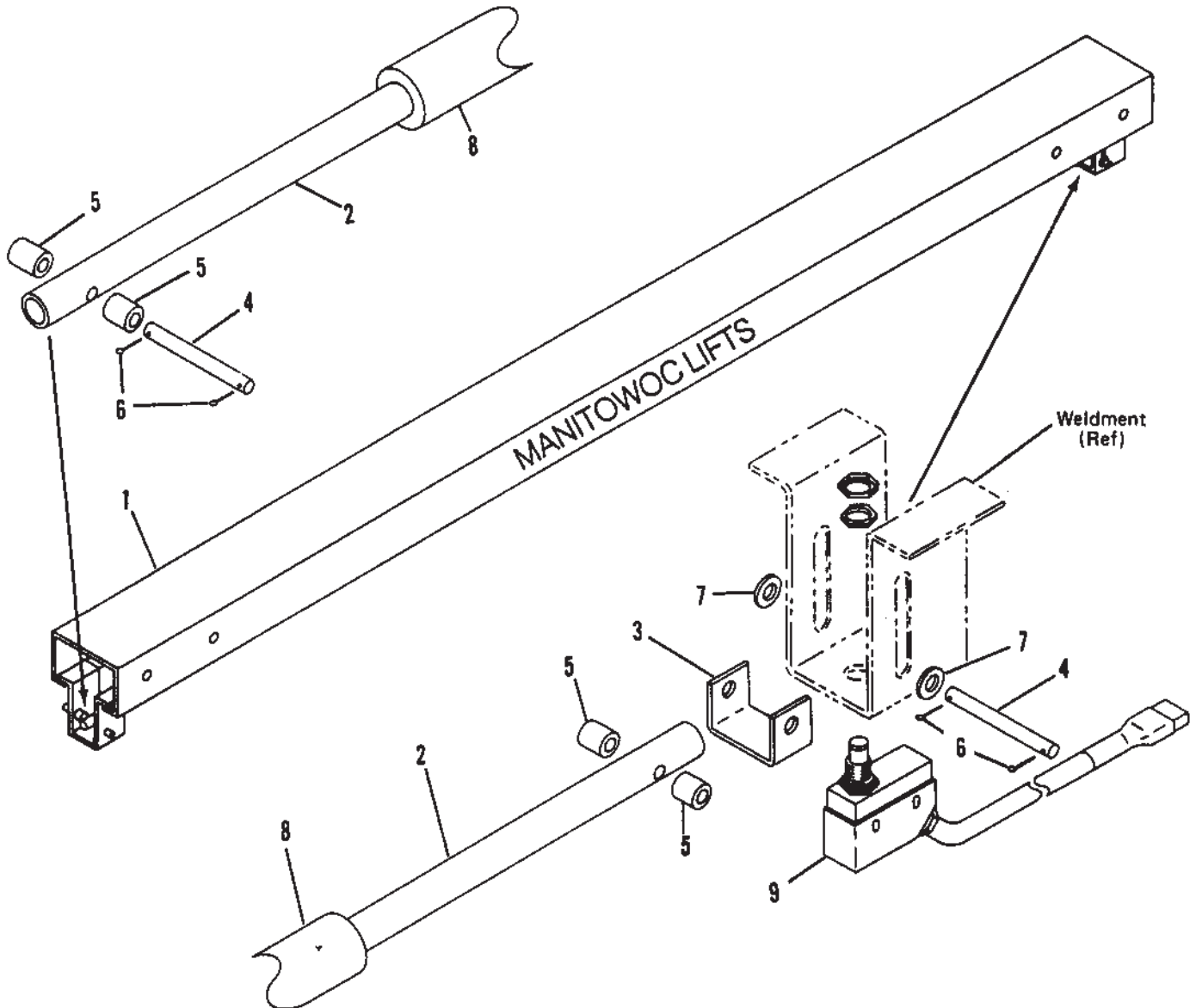

BRIDGE CENTER

When ordering replacement parts, always mention lift model number and serial number.

NOTE:

Items 1, 2, 3, & 4 do not include lift pad and roll pin.

NOTE:

Arm locks must be installed in position shown

NOTE:

Items 13, 14, and 15 are optional 4-piece kits.

Item No.	No. Req.	Part No.	Description
1	1	R18230-256	Drive Arm (Short)
2	1	R18230-257	Slave Arm (Short)
3	1	R18230-258	Drive Arm (Long)
4	1	R18230-259	Slave Arm (Long)
5	4	R18230-86	Arm Pin
6	4	R18230-136	1/4-20 X 5/8 Tap Bolt
7	4	R18230-54	Lift Pad
8	4	R18230-125	Roll Pin 1/8 Dia. x 1-3/8
9	8	R18230-245	Pin
10	8	R18230-122	Cotter Pin 1/8" Dia. x 1"
11	2	R18230-246	Arm Lock Ass'y (Short)
12	2	R18230-247	Arm Lock Ass'y (Long)
13	1	K93223	Kit of (4) Pads
14	1	K93216	Height Adapter Kit, 4"
15	1	K93218	Height Adapter Kit, 8"

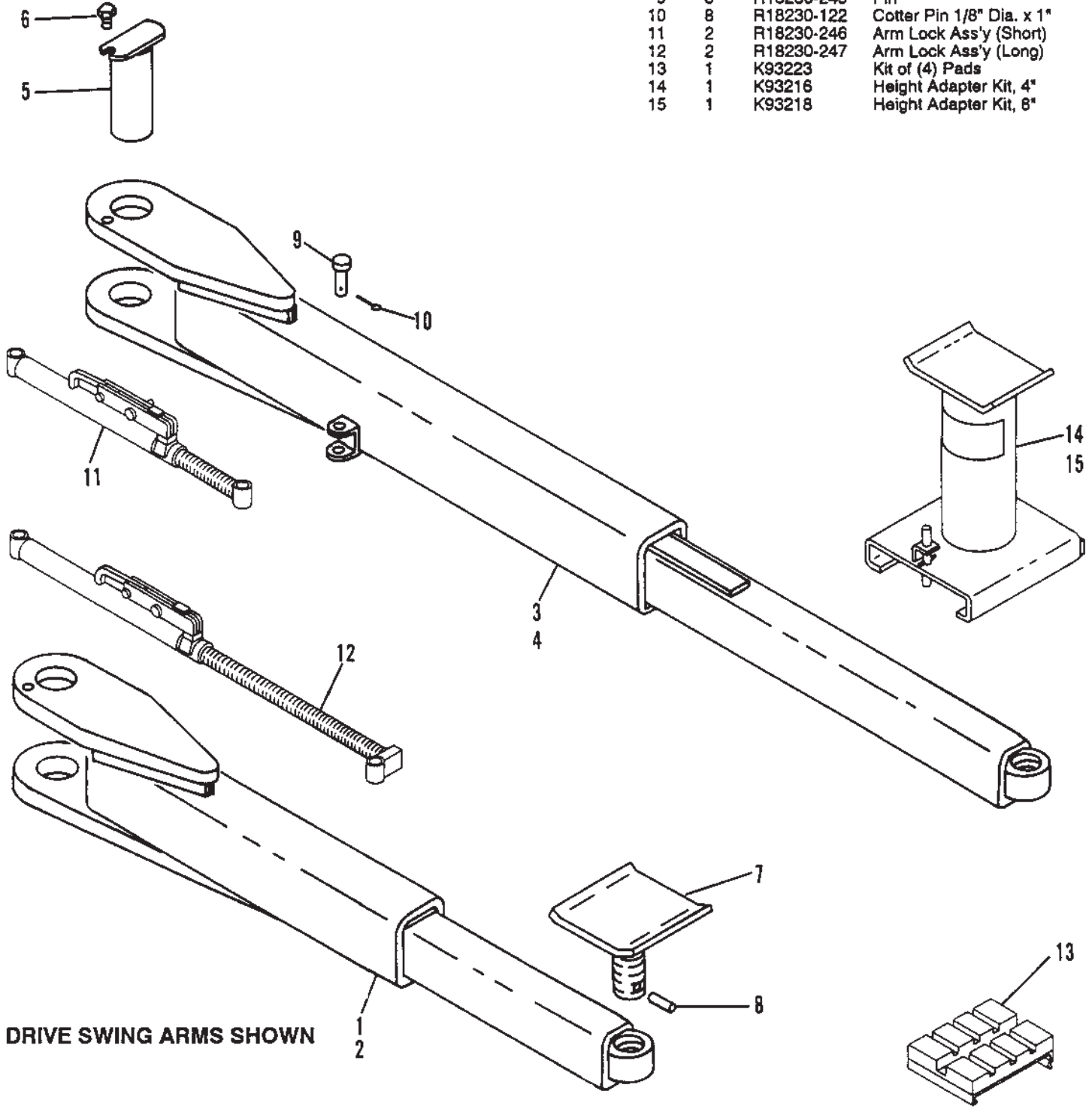

DRIVE SWING ARMS SHOWN

SWING ARMS & ARM LOCKS

When ordering replacement parts, always mention lift model number and serial number.

Item No.	No. Req.	Part No.	Description
1	2	R18230-87	Cylinder
2	1	R18230-88	Chain Sheave
3	1	R18230-89	Shaft
4	1	R18230-135	1/4-20 x 3/8 Loc. Set Screw
5	1	R18230-133	No. 10-32 x 5/16 Bleeder Screw
6	1	R18230-58	Bleeder Washer
7	1	R18230-122	Cotter Pin 1/8 Dia. x 1
8	2	K03782	Hex Hd. Bolt 5/16-18 x 1-3/4
9	2	K79695	Expansion Shield
10	1	T07915	Wheel Locator Plate
11	1	K34159	Seal Kit

NOTE!

Item No. 2 thru No. 7 are the quantity required per cylinder, for entire lift, double quantities.

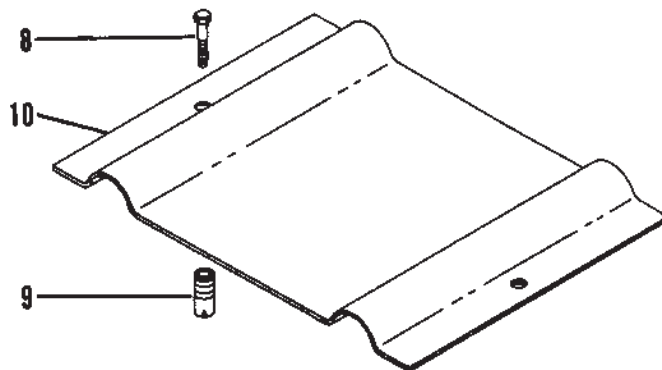
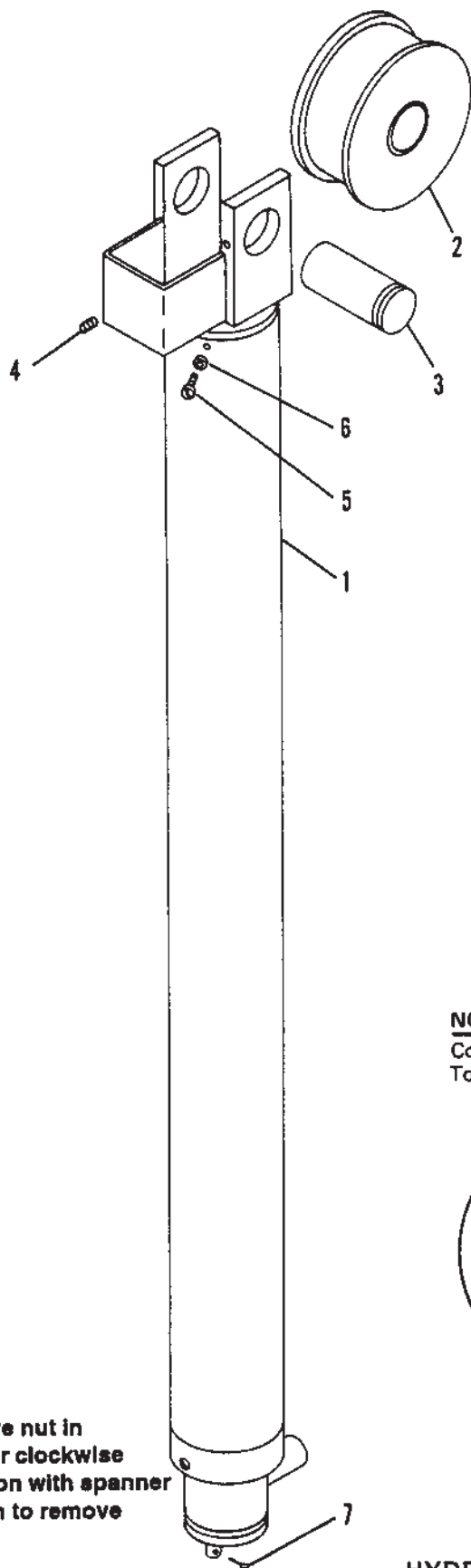

NOTE:
Concave Side
Toward "O" Ring

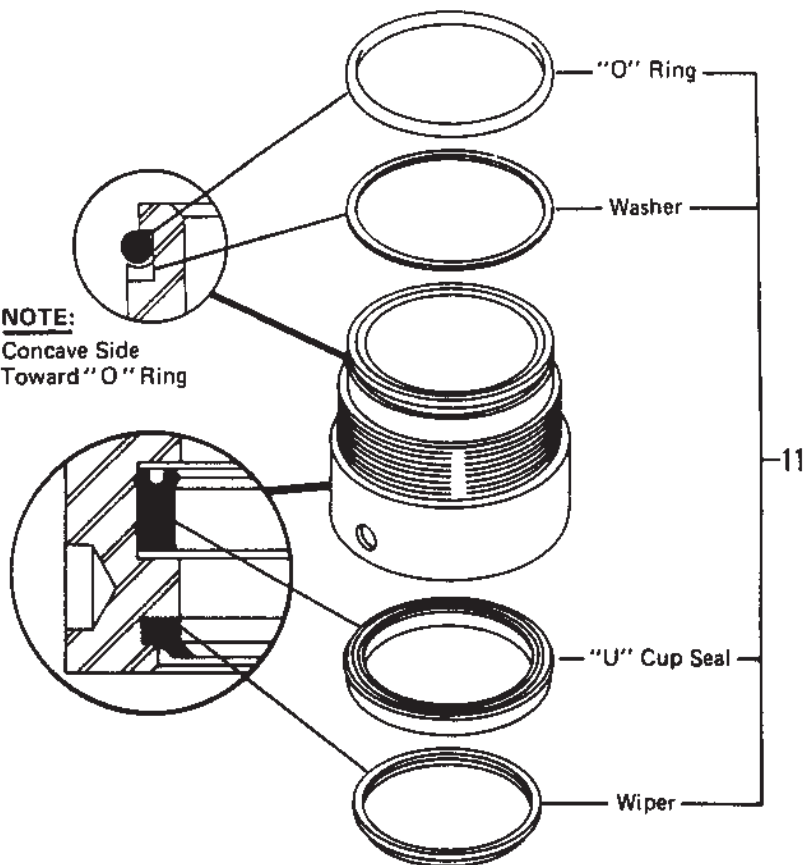

NOTE! Seal Kit does not include nut

NOTE!
Remove nut in
counter clockwise
direction with spanner
wrench to remove
seal.

HYDRAULIC CYLINDER

When ordering replacement parts, always mention lift model number and serial number.

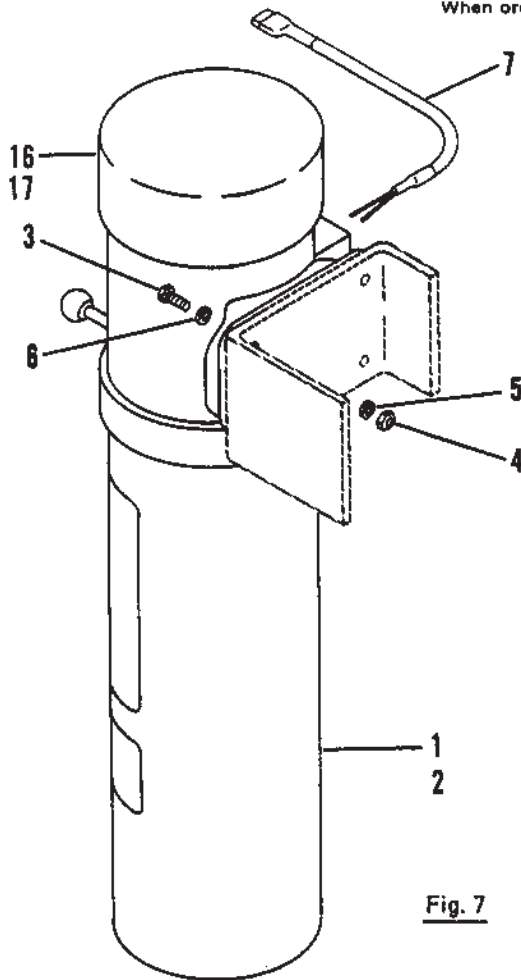
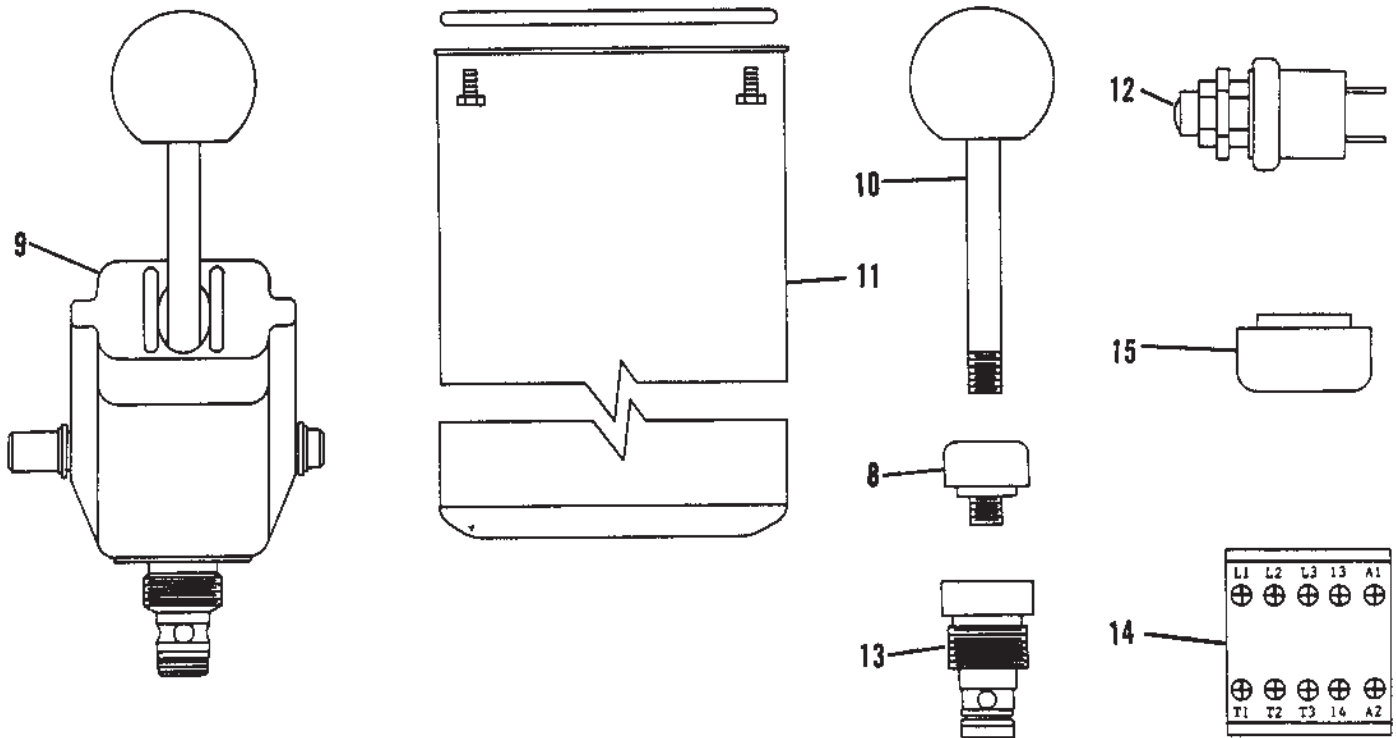

Fig. 7

Item No.	No. Req.	Part No.	Description
1	1	K93226	Power Unit (208/230V., 1 PH.)
2	1	K93227	Power Unit (200/230V., 3 PH.)
3	4	R18230-140	5/16-18 x 1" Bolt
4	4	R18230-141	5/16-18 Hex Nut
5	4	R18230-142	5/16 Dia. Lock Washer
6	4	R18230-143	5/16 Dia. Flat Washer
7	1	R18230-102	Switch Pigtail
8	1	R18230-103	Breather
9	1	R18230-104	Release Valve Kit (Valve, Linkage, Handle)
10	1	R18230-105	Stud & Ball
11	1	R18230-106	Reservoir Kit (Tank, O Ring, Fasteners)
12	1	R18230-107	3 PH. Switch
12	1	R18230-110	1 PH. Switch
13	1	R18230-108	Check Valve (Valve, Seals)
14	1	R18230-111	3 PH. Contactor
15	1	R18230-112	Filter
16	1	R18230-193	Motor Assem. 1 PH.
17	1	R18230-194	Motor Assem. 3 PH.

**BARNES ORIGINAL DESIGN POWER UNIT
(WITH FAN COOLED MOTOR AND CAM
ACTIVATED RELEASE VALVE)**

POWER UNIT



REPLACEMENT PARTS

When ordering replacement parts, always mention lift model number and serial number.

Item No.	No. Req.	Part No	Description
1	1	K93272	Power Unit (208/230V., 1 PH.)
2	1	K93273	Power Unit (200/230V., 3 PH.)
3	4	R18230-140	5/16-18 x 1" Bolt
4	4	R18230-141	5/16-18 Hex Nut
5	4	R18230-142	5/16 Dia. Lock Washer
6	4	R18230-143	5/16 Dia. Flat Washer
7	1	R18230-102	Switch Pigtail
8	1	R18230-103	Breather
9	1	R18230-195	Release Valve
10	1	R18230-196	Handle Kit
11	1	R18230-106	Reservoir Kit (Tank, O Ring, Fasteners)
12	1	R18230-107	3 PH. Switch
13	1	R18230-110	1 PH. Switch
14	1	R18230-108	Check Valve (Valve, Seals)
15	1	R18230-111	3 PH. Contactor
16	1	R18230-112	Filter
17	1	R18230-193	Motor Assem. 1 PH.
18	1	R18230-194	Motor Assem. 3 PH.

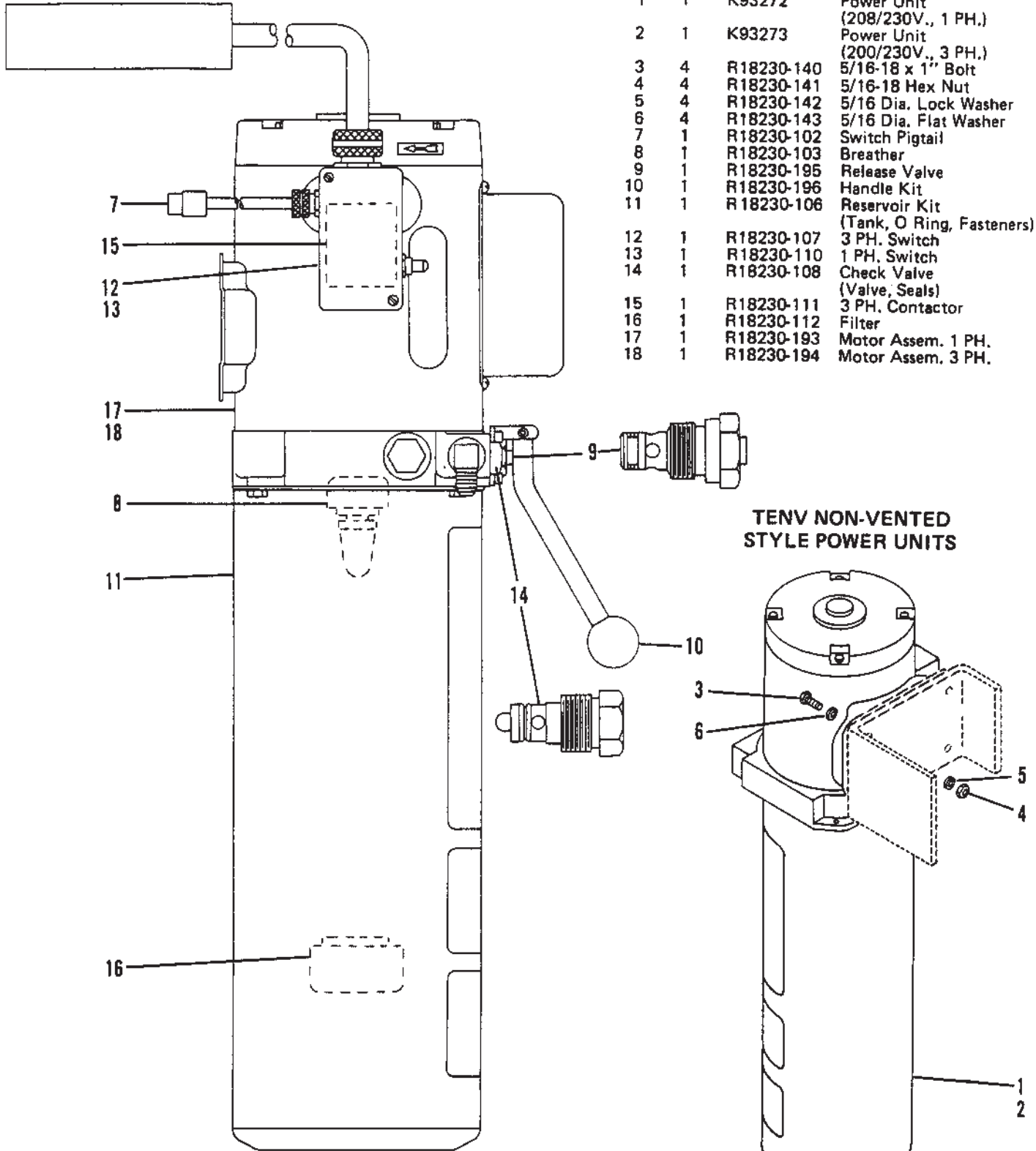

BARNES POWER UNIT WITH PIGTAIL CONNECTOR

POWER UNIT

Fig. 7

When ordering replacement parts, always mention lift model number and serial number.

Item No.	No. Req.	Part No	Description
1	1	K93272	Power Unit (208/230V., 1 PH.)
2	1	K93273	Power Unit (200/230V., 3 PH.)
3	4	R18230-140	5/16-18 x 1" Bolt
4	4	R18230-141	5/16-18 Hex Nut
5	4	R18230-142	5/16 Dia. Lock Washer
6	4	R18230-143	5/16 Dia. Flat Washer
7	1	R18230-235	Connector
8	1	R18230-103	Breather
9	1	R18230-195	Release Valve
10	1	R18230-196	Handle Kit
11	1	R18230-106	Reservoir Kit (Tank, O Ring, Fasteners)
12	1	R18230-107	3 PH. Switch
13	1	R18230-110	1 PH. Switch
14	1	R18230-108	Check Valve (Valve, Seals)
15	1	R18230-111	3 PH. Contactor
16	1	R18230-112	Filter
17	1	R18230-193	Motor Assem. 1 PH.
18	1	R18230-194	Motor Assem. 3 PH.

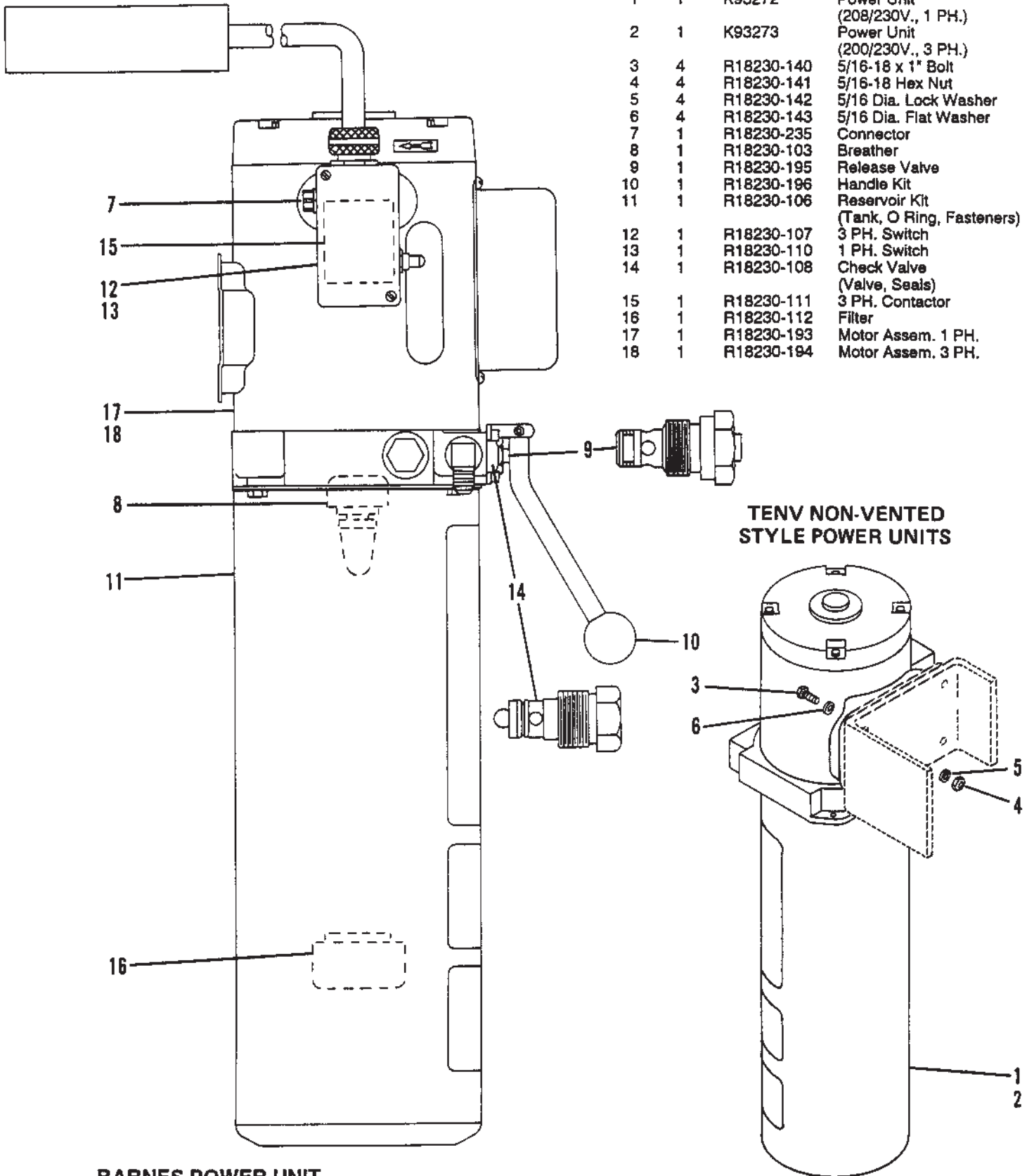

TENV NON-VENTED STYLE POWER UNITS

BARNES POWER UNIT WITH FLUSH MOUNTED CONNECTOR

POWER UNIT

Fig. 7

When ordering replacement parts, always mention lift model number and serial number.

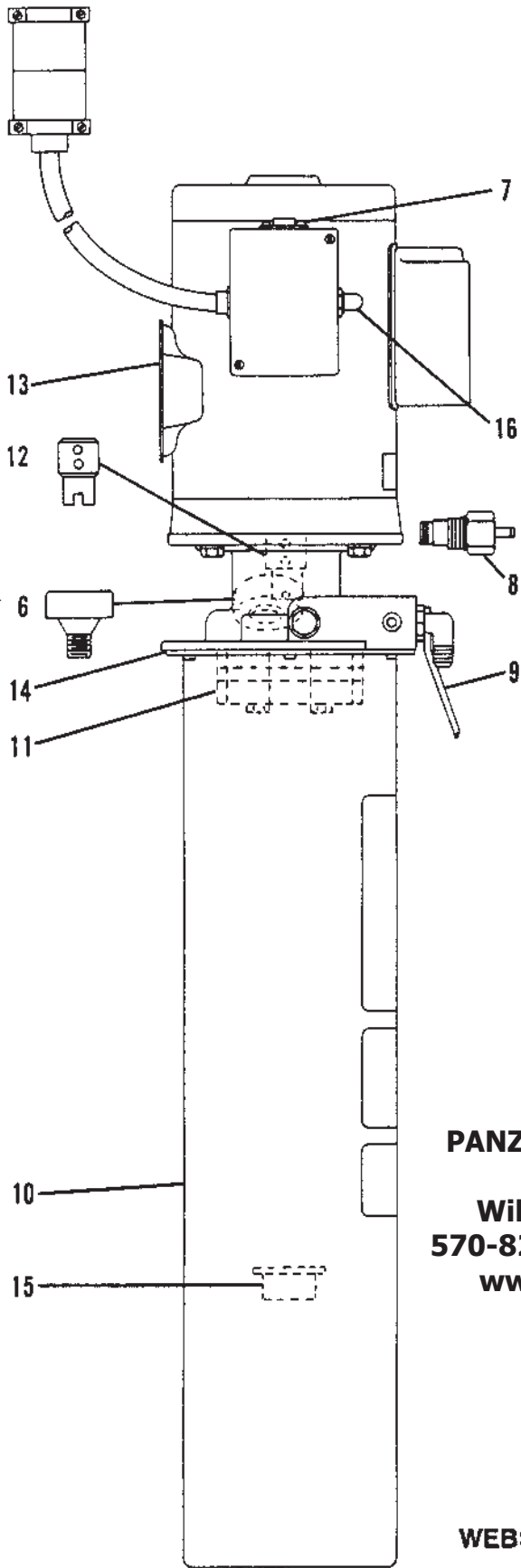

Item No.	No. Req.	Part No.	Description
1	1	K93272	Power Unit (208/230V., 1 PH.)
2	4	R18230-140	5/16-18 x 1" Bolt
3	4	R18230-141	5/16-18 Hex Nut
4	4	R18230-142	5/16 Dia. Lock Washer
5	4	R18230-143	5/16 Dia. Flat Washer
6	1	R18230-270	Breather
7	1	R18230-235	Connector
8	1	R18230-271	Manual Valve Assm.
9	1	R18230-272	Handle Kit
10	1	R18230-273	Tank Kit
11	1	R18230-274	Pump Assm.
12	1	R18230-275	Motor Hdwe. Kit
13	1	R18230-269	Motor Assm. 1 PH.
14	1	R18230-276	Tank Gasket
15	1	R18230-277	Inlet Strainer
16	1	R18230-278	Motor Switch Kit

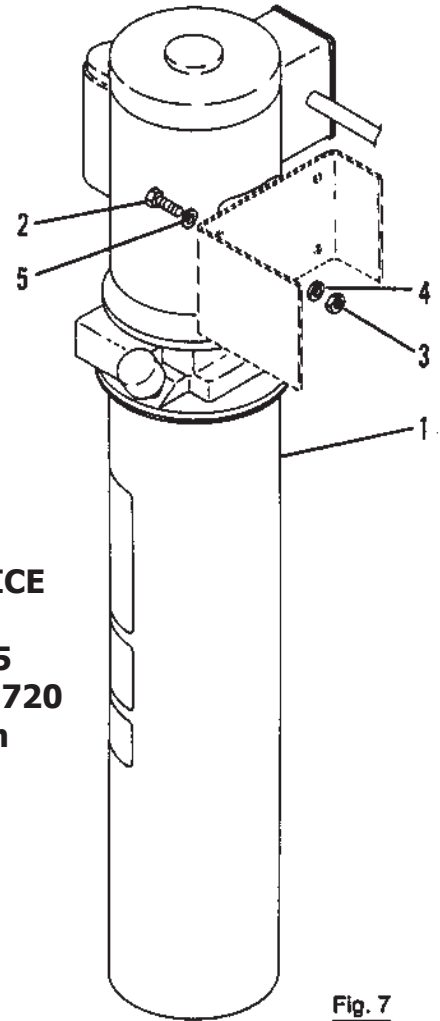

PANZITTA SALES & SERVICE
 72 George Avenue
 Wilkes-Barre, PA 18705
 570-822-6720 800-822-6720
 www.panzittasales.com

WEBSTER POWER UNIT

Fig. 7