

PANZITTA SALES & SERVICE
72 George Avenue
Wilkes-Barre, PA 18705
570-822-6720 800-822-6720
www.panzittasales.com

MANITOWOC LIFTS

INSTALLATION INSTRUCTIONS AND PARTS LIST

CBT-90

BASE TYPE LIFT

F-52C40D0500 (208/230V., 1PH.)

F-52C50D0500 (200/230V., 3PH.)

**LIFT CAPACITY 9,000 LBS.
2,250 LBS. PER SWING ARM**

When ordering replacement parts, always mention lift model number and serial number.

Item No.	No. Req.	Part No.	Description
1	1	R18230-218	Column Weldment (Drive)
2	1	R18230-115	Base Angle
3	2	R18230-124	Cotter Pin
4	1	R18230-220	Cable Sheave
5	1	R18230-229	Pin
6	2	R18230-121	Cotter Pin
7	4	R18230-170	Anchor Bolt
8	2	R18230-173	3/4"-10 x 2" Bolt
9	1	R18230-222	Column Sheave Bkt.
10	2	R18230-171	3/4" Dia. Lock Washer
11	6	R18230-172	3/4" Dia. Flat Washer
12	4	R18230-160	5/8-11 x 1-3/4" Bolt
13	4	R18230-162	5/8-11 Hex Nut
14	4	R18230-164	5/8" Dia. Lock Washer
15	4	R18230-166	5/8" Dia. Flat Washer
16	2	R18230-09	7" Bumper
17	2	R18230-92	12" Bumper
18	1	R18230-221	Pin
19	2	R18230-224	Cable Sheave Washer
20	2	R18230-230	Washer

PANZITTA SALES & SERVICE
 72 George Avenue
 Wilkes-Barre, PA 18705
 570-822-6720 800-822-6720
 www.panzittasales.com

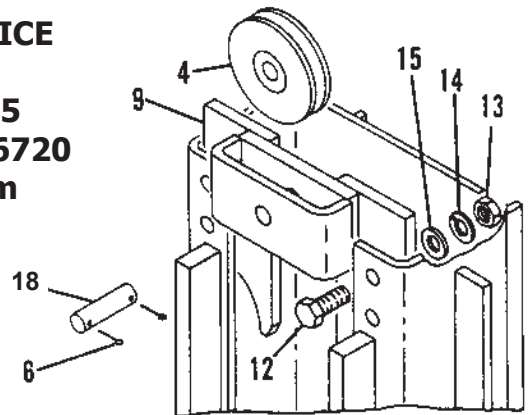
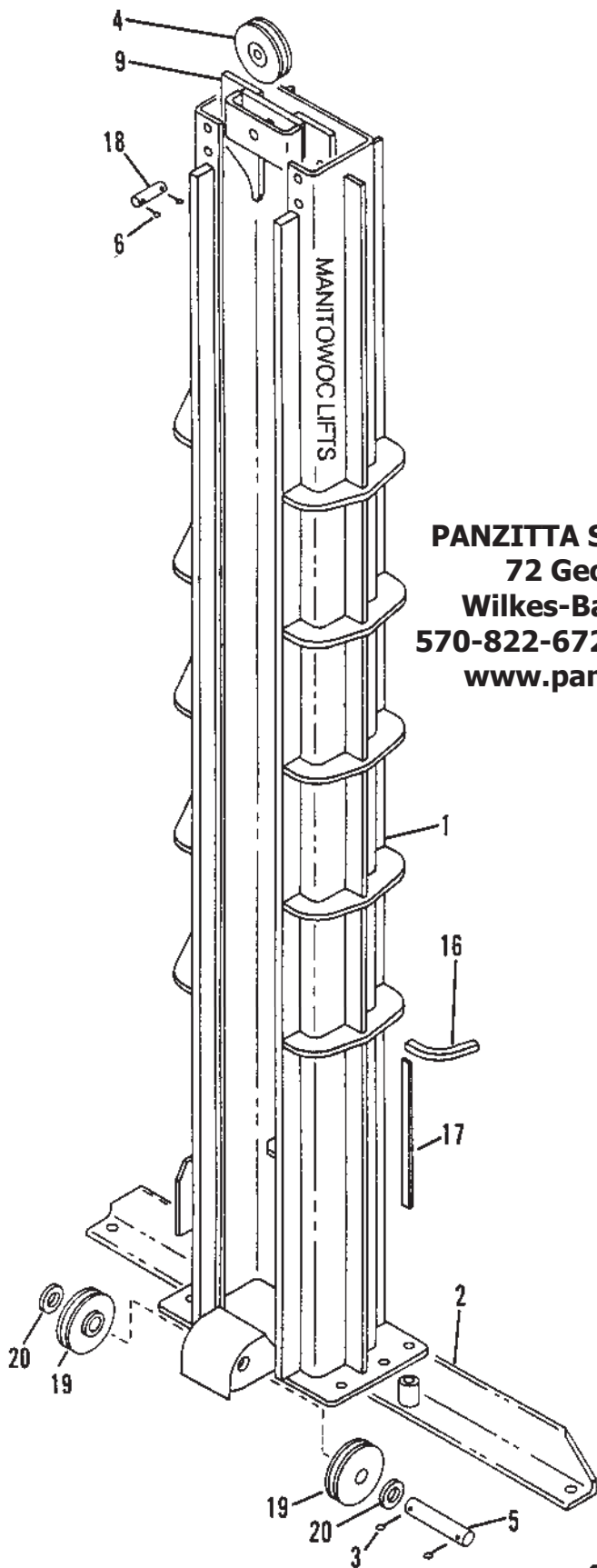
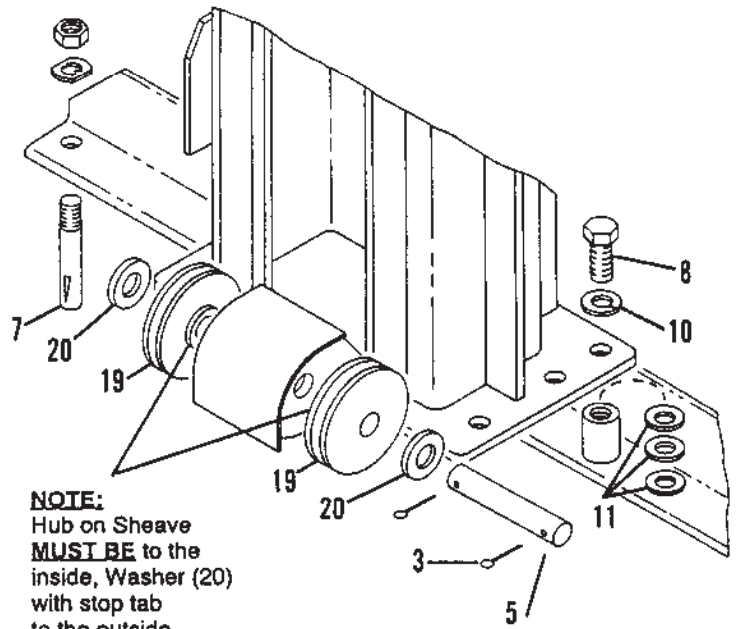

Fig. 13



COLUMN (DRIVE SIDE)

When ordering replacement parts, always mention lift model number and serial number.

Item No.	No. Req.	Part No.	Description
1	1	R18230-219	Column Weldment (Slave)
2	1	R18230-115	Base Angle
3	2	R18230-124	Cotter Pin
4	1	R18230-220	Cable Sheave
5	1	R18230-229	Pin
6	2	R18230-121	Cotter Pin
7	4	R18230-170	Anchor Bolt
8	2	R18230-173	3/4"-10 x 2" Bolt
9	1	R18230-222	Column Sheave Bkt.
10	2	R18230-171	3/4" Dia. Lock Washer
11	6	R18230-172	3/4" Dia. Flat Washer
12	4	R18230-160	5/8-11 x 1-3/4" Bolt
13	4	R18230-162	5/8-11 Hex Nut
14	4	R18230-164	5/8" Dia. Lock Washer
15	4	R18230-166	5/8" Dia. Flat Washer
16	2	R18230-09	7" Bumper
17	2	R18230-82	12" Bumper
18	1	R18230-221	Pin
19	2	R18230-224	Cable Sheave Washer
20	2	R18230-230	Washer

PANZITTA SALES & SERVICE
 72 George Avenue
 Wilkes-Barre, PA 18705
 570-822-6720 800-822-6720
 www.panzittasales.com

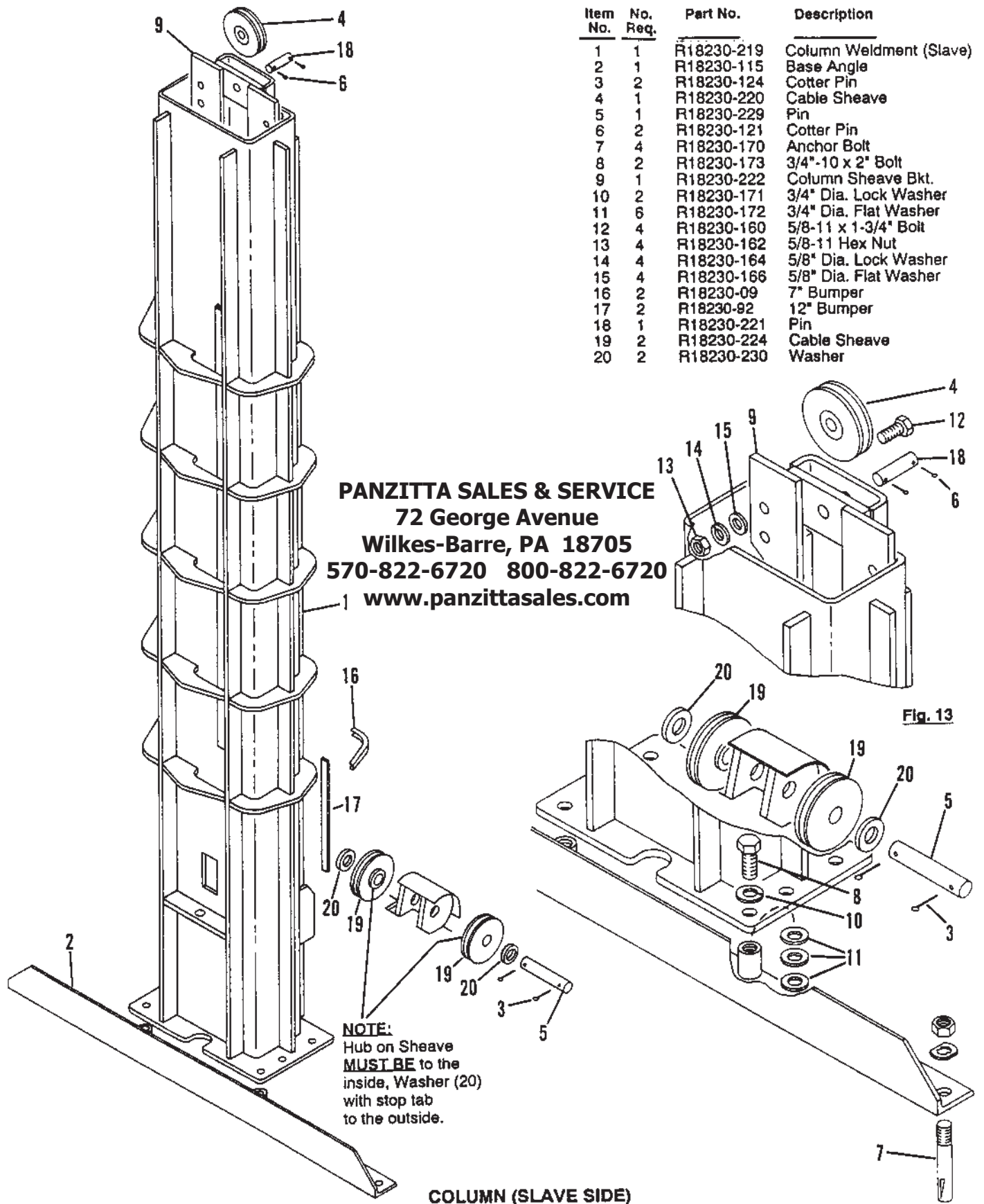

When ordering replacement parts, always mention lift model number and serial number.

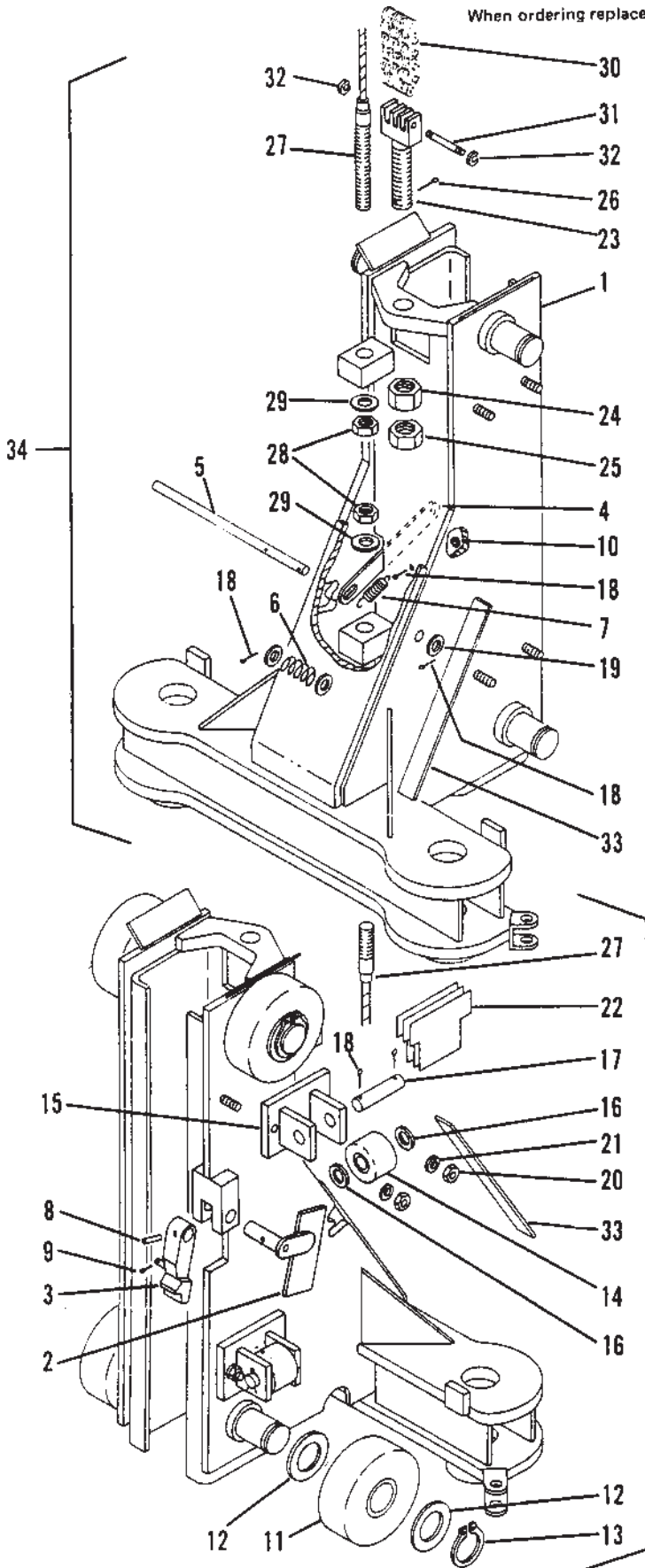

Item No.	No. Req.	Part No.	Description
1	2	R18230-225	Carriage Weldment
2	1	R18230-13	Counterweight
3	1	R18230-70	Safety Dog
4	1	R18230-15	Link
5	1	R18230-16	Lever
6	1	R18230-17	Compression Spring
7	1	R18230-18	Extension Spring
8	1	R18230-127	Roll Pin 3/16" Dia. x 1
9	1	R18230-120	Cotter Pin 1/16" Dia. x 1/2
10	1	R18230-131	No. 6 SAE Flat Washer
11	4	R18230-19	Roller (Main)
12	8	R18230-20	Thrust Washer (Large)
13	4	R18230-21	Retaining Ring
14	4	R18230-22	Roller (Side)
15	4	R18230-23	Bracket
16	8	R18230-24	Thrust Washer (Small)
17	4	R18230-25	Pin (Side Roller)
18	11	R18230-122	Cotter Pin 1/8" Dia. x 1
19	3	R18230-148	3/8" Dia. Flat Washer
20	8	R18230-146	3/8-16 Hex Nut
21	8	R18230-147	3/8" Dia. Lock Washer
22	2	R18230-26	Shim Pack (Carriage)
23	1	R18230-72	Chain Retainer
24	1	R18230-175	7/8-9 Hex Nut
25	1	R18230-176	7/8-9 Hex Jam Nut
26	1	R18230-121	Cotter Pin 1/8" Dia. x 1-1/4
27	1	R18230-223	Wire Rope
28	2	R18230-168	3/4-10 Nylon Insert Nut
29	2	R18230-169	3/4" Dia. SAE Flat Washer
30	1	R18230-74	Leaf Chain
31	2	R18230-75	Chain Pin
32	4	R18230-31	Retaining Ring
33	2	R18230-32	Rubber Bumper
34	2	R18230-226	Carriage Complete

NOTE!

Items No. 2 thru No. 33 are quantity required per carriage, for entire lift, double quantities.

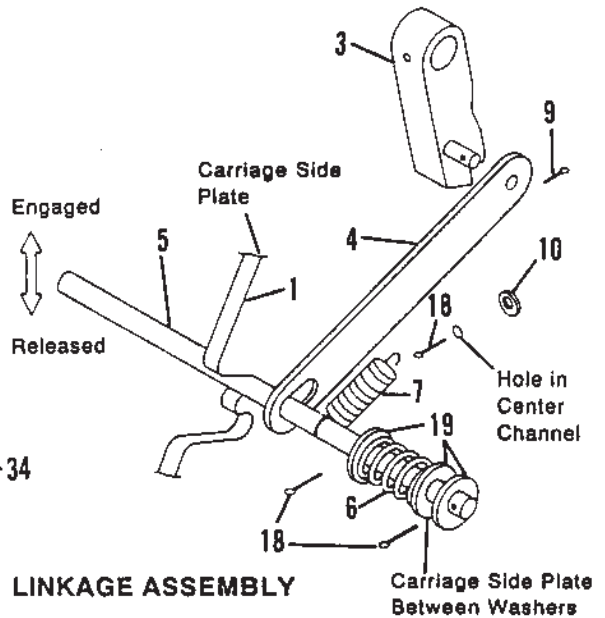

CARRIAGE

PANZITTA SALES & SERVICE
 72 George Avenue
 Wilkes-Barre, PA 18705
 570-822-6720 800-822-6720
 www.panzittasales.com

When ordering replacement parts, always mention lift model number and serial number.

Item No.	No. Req.	Part No.	Description
1	1	R18230-233	Hose 3/8" x 52"
2	1	R18230-234	Hose 1/4" x 162"
3	1	R18230-90	90° Fitting
4	1	R18230-129	Tee Fitting
5	1	R18230-190	90° Fitting (Long)

PANZITTA SALES & SERVICE
 72 George Avenue
 Wilkes-Barre, PA 18705
 570-822-6720 800-822-6720
 www.panzittasales.com

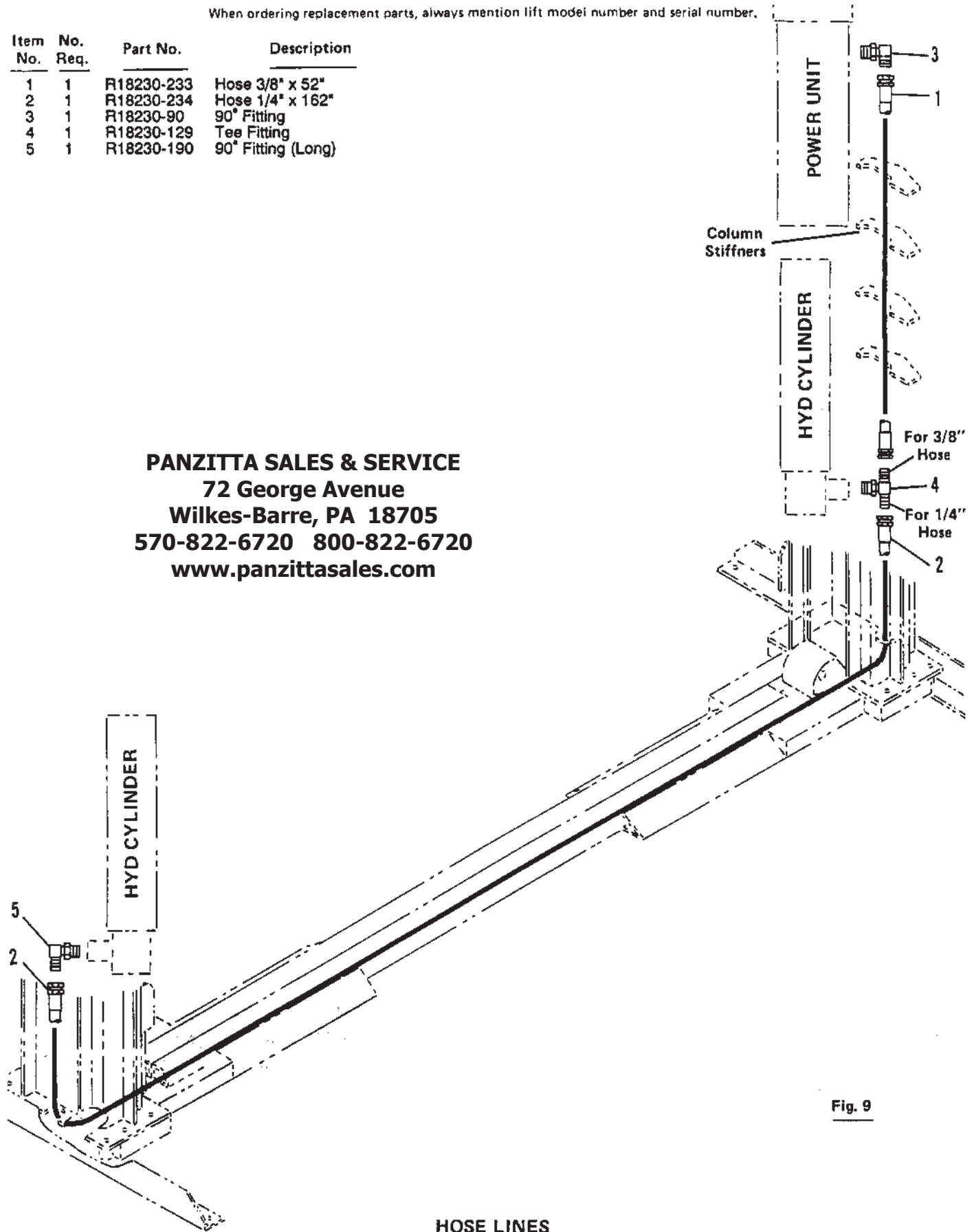
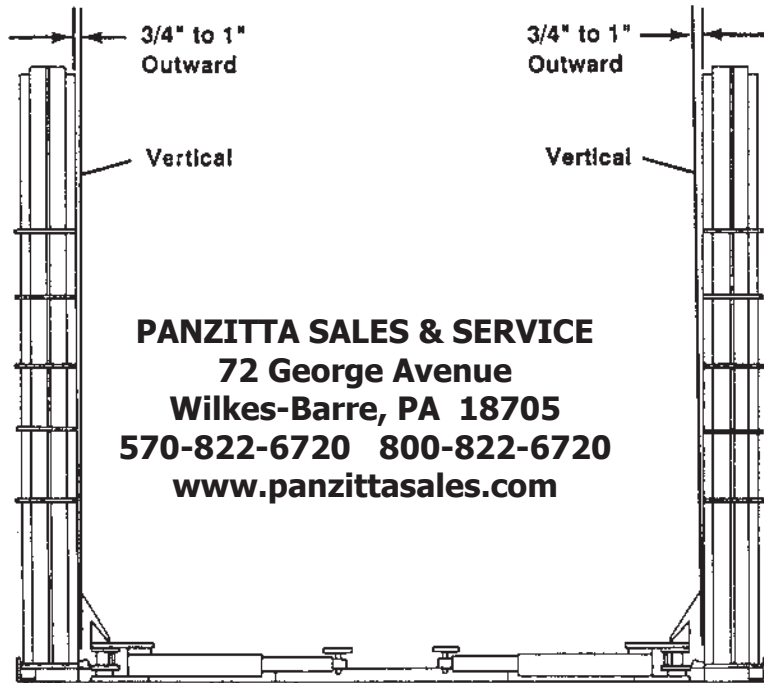

Fig. 9

HOSE LINES

When ordering replacement parts, always mention lift model number and serial number.

Item No.	No. Req.	Part No.	Description
1	1	K93239	Base Assembly
2	2	R18230-170	Anchor Bolt
3	4	R18230-08	Shim Pack
4	8	R18230-173	3/4"-10 x 2" Bolt
5	8	R18230-171	3/4" Dia. Lockwasher



PANZITTA SALES & SERVICE
 72 George Avenue
 Wilkes-Barre, PA 18705
 570-822-6720 800-822-6720
 www.panzittasales.com

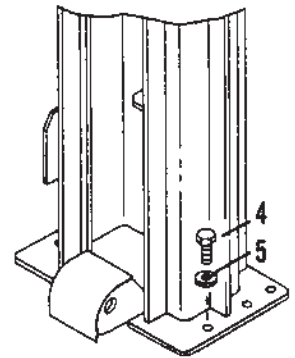
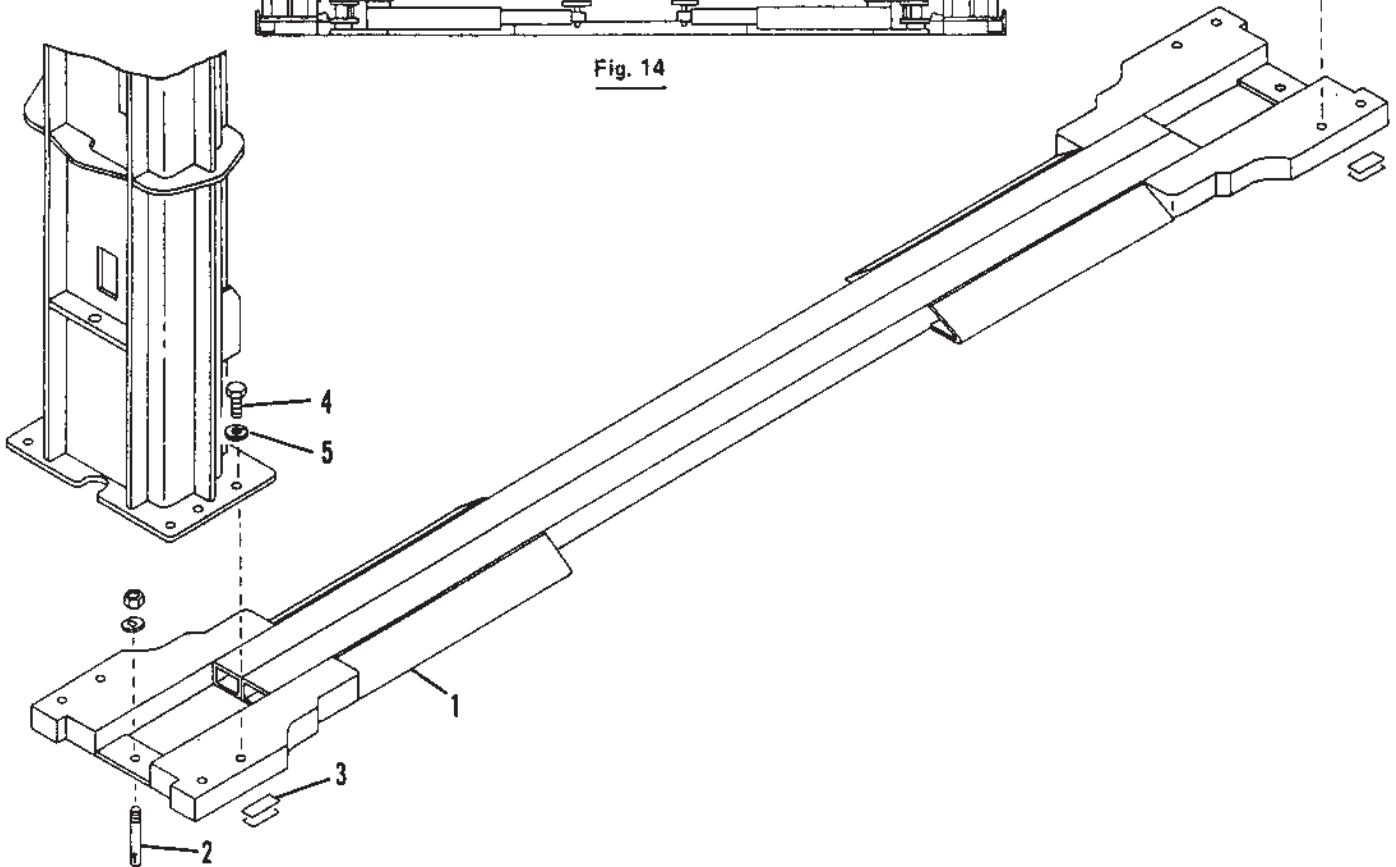

Fig. 14



BASE ASSEMBLY

When ordering replacement parts, always mention lift model number and serial number.

NOTE:

Items 1 & 2 do not include lift pad and roll pin.

NOTE:

Arm locks must be installed in position shown

NOTE:

Items 10, 11, and 12 are optional 4-piece kits.

One set of right & left swing arms shown.

Item No.	No. Req.	Part No.	Description
1	2	R18230-266	Arm (Right)
2	2	R18230-267	Arm (Left)
3	4	R18230-232	Arm Pin
4	4	R18230-136	1/4-20 x 5/8 Tap Bolt
5	4	R18230-54	Lift Pad
6	4	R18230-125	Roll Pin 1/8 Dia. x 1-3/8
7	8	R18230-245	Pin
8	8	R18230-122	Cotter Pin 1/8" Dia. x 1"
9	4	R18230-246	Arm Lock Ass'y
10	1	K93223	Kit of (4) Pads
11	1	K93216	Height Adapter Kit, 4"
12	1	K93218	Height Adapter Kit, 8"

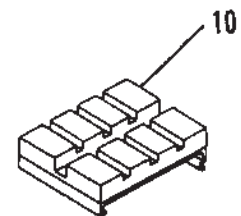
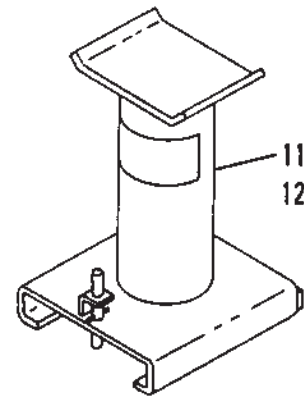
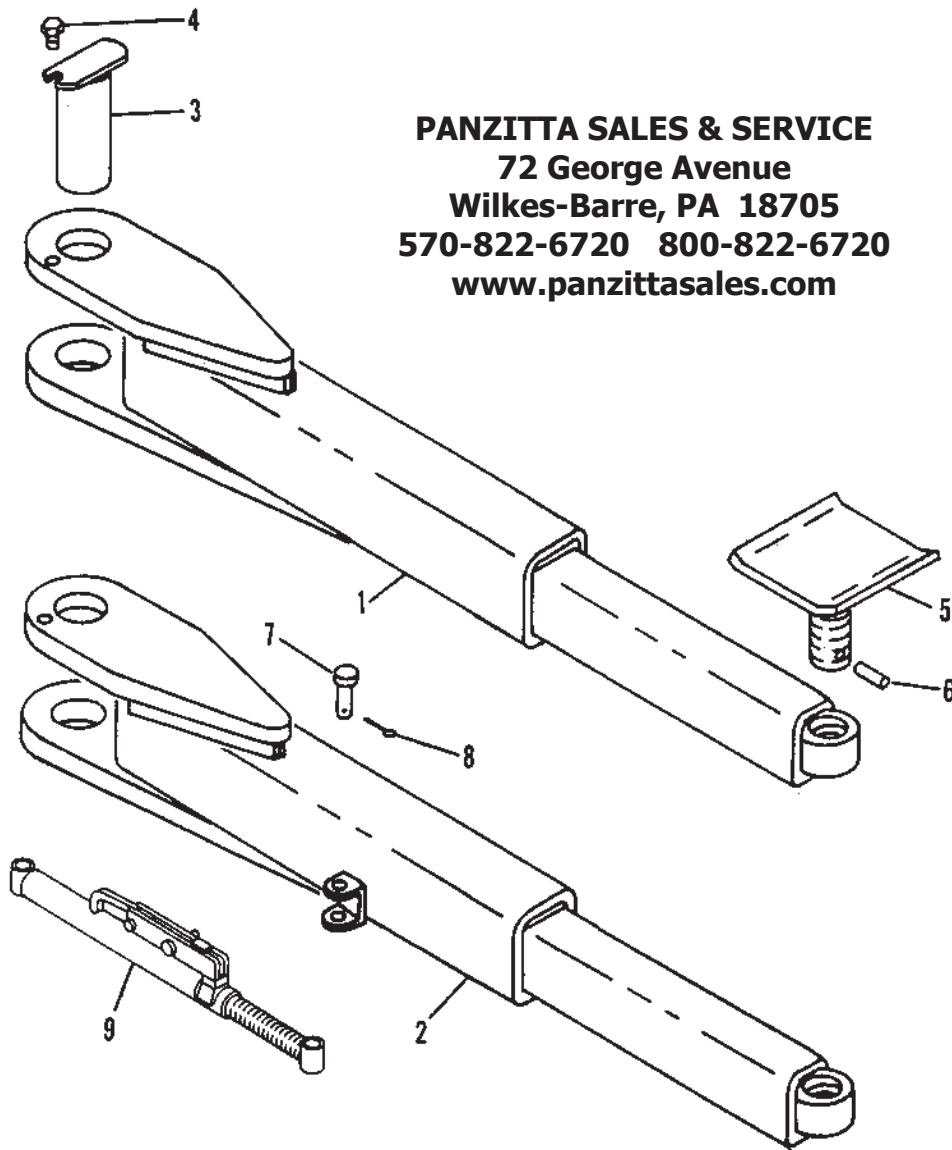

PANZITTA SALES & SERVICE
 72 George Avenue
 Wilkes-Barre, PA 18705
 570-822-6720 800-822-6720
 www.panzittasales.com

SWING ARMS & ARM LOCKS

When ordering replacement parts, always mention lift model number and serial number.

Item No.	No. Reg.	Part No.	Description
1	2	R18230-87	Cylinder
2	1	R18230-88	Chain Sheave
3	1	R18230-89	Shaft
4	1	R18230-135	1/4-20 x 3/8 Loc. Set Screw
5	1	R18230-133	No. 10-32 x 5/16 Bleeder Screw
6	1	R18230-58	Bleeder Washer
7	1	R18230-122	Cotter Pin 1/8 Dia. x 1
8	2	K03782	Hex Hd. Bolt 5/16-18 x 1-3/4
9	2	K79695	Expansion Shield
10	1	T07915	Wheel Locator Plate
11	1	K34159	Seal Kit

NOTE!

Item No. 2 thru No. 7 are the quantity required per cylinder, for entire lift, double quantities.

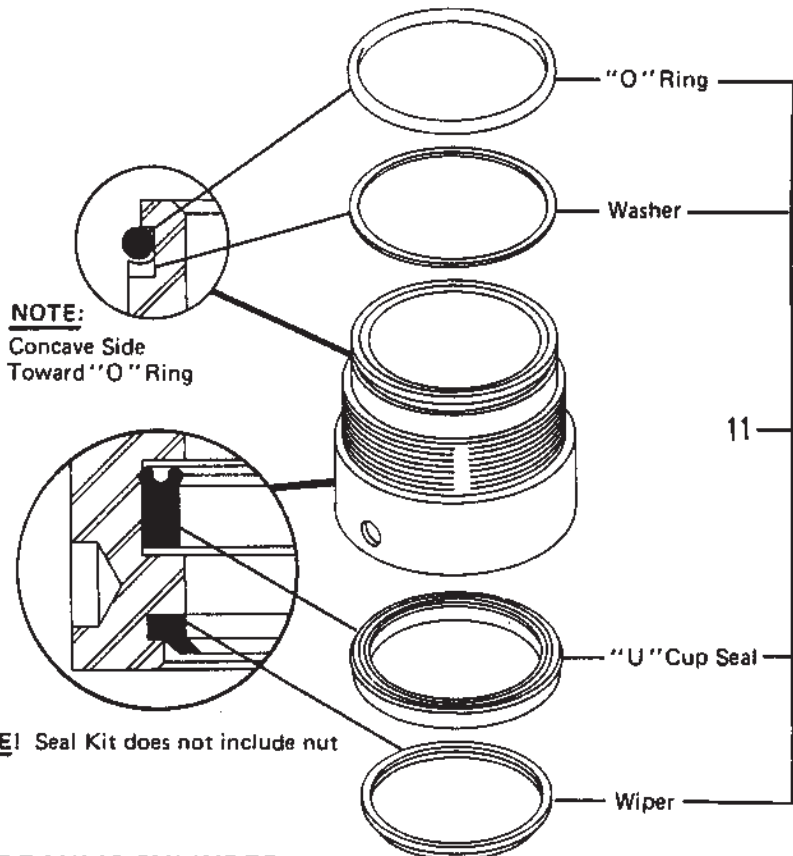
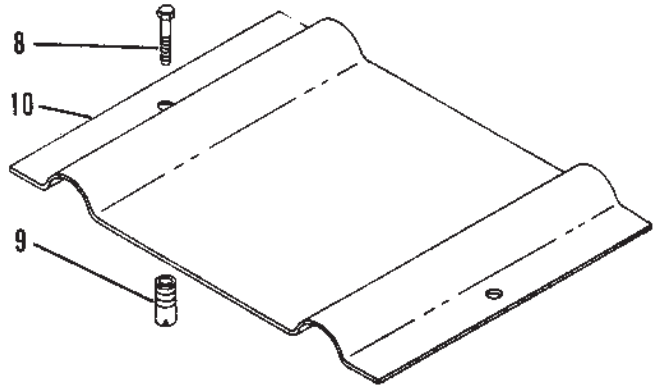
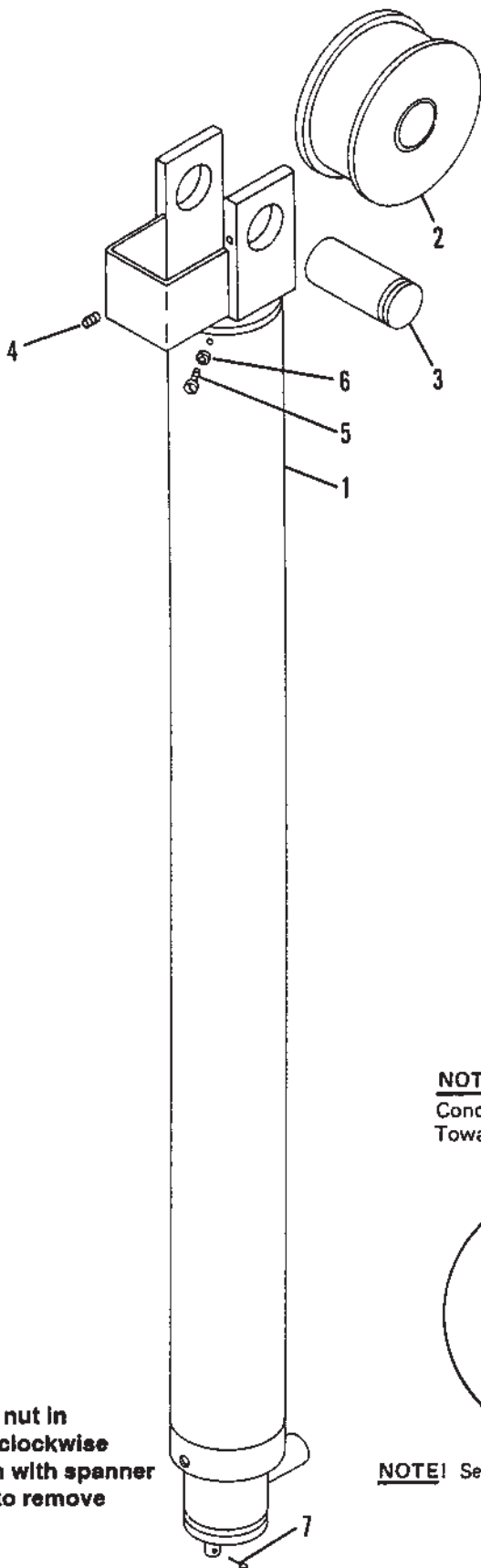

NOTE:
Concave Side
Toward "O" Ring

NOTE! Seal Kit does not include nut

NOTE!
Remove nut in
counter clockwise
direction with spanner
wrench to remove
seal.

HYDRAULIC CYLINDER

CBT-00

PANZITTA SALES & SERVICE
72 George Avenue
Wilkes-Barre, PA 18705
570-822-6720 800-822-6720
www.panzittasales.com

When ordering replacement parts, always mention lift model number and serial number

Item No.	No. Req.	Part No.	Description
1	1	K93563	Power Unit (208/230V., 1PH.)
2	1	K93564	Power Unit (200/230V., 3PH.)
3	4	R18230-140	5/16-18 x 1" Bolt
4	4	R18230-141	5/16-18 Hex Nut
5	4	R18230-142	5/16 Dia. Lock Washer
6	4	R18230-143	5/16 Dia. Flat Washer
7	1	R18230-112	Filter
8	1	R18230-103	Breather
9	1	R18230-195	Release Valve
10	1	R18230-196	Handle Kit
11	1	R18230-106	Reservoir Kit (Tank, O Ring, Fasteners)
12	1	R18230-107	3PH. Switch
13	1	R18230-110	1PH. Switch
14	1	R18230-108	Check Valve (Valve, Seals)
15	1	R18230-111	3PH. Contactor
16	1	R18230-227	Motor Assem. 1 PH.
17	1	R18230-228	Motor Assem. 3PH.

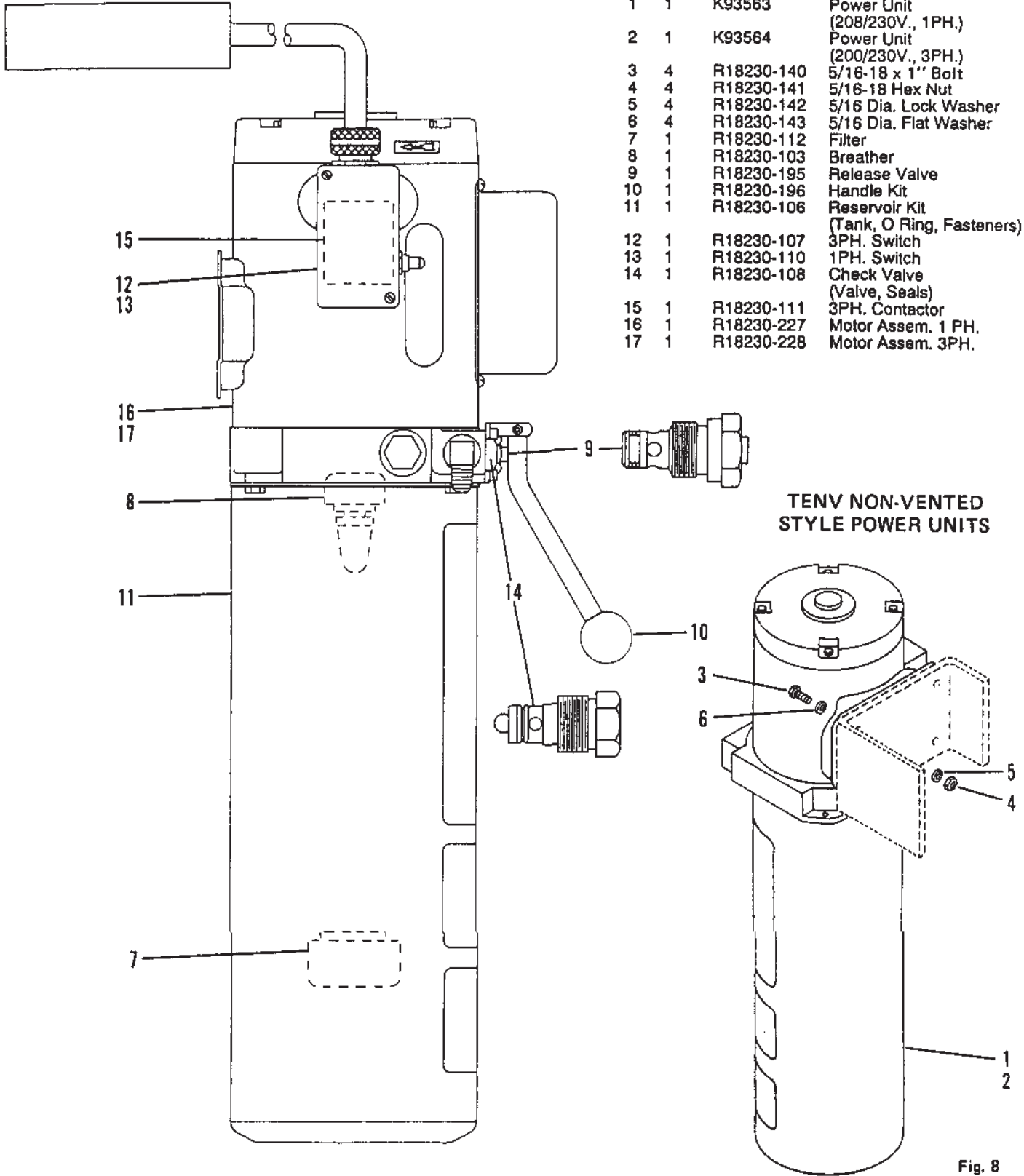

BARNES POWER UNIT

POWER UNIT

Fig. 8

PANZITTA SALES & SERVICE
 72 George Avenue
 Wilkes-Barre, PA 18705
 570-822-6720 800-822-6720
 www.panzittasales.com

When ordering replacement parts, always mention lift model number and serial number

Item No.	No. Req.	Part No.	Description
1	1	K93272	Power Unit (208/230V., 1PH.)
2	1	K93273	Power Unit (200/230V., 3PH.)
3	4	R18230-140	5/16-18 x 1" Bolt
4	4	R18230-141	5/16-18 Hex Nut
5	4	R18230-142	5/16 Dia. Lock Washer
6	4	R18230-143	5/16 Dia. Flat Washer
7	1	R18230-112	Filter
8	1	R18230-103	Breather
9	1	R18230-195	Release Valve
10	1	R18230-196	Handle Kit
11	1	R18230-106	Reservoir Kit (Tank, O Ring, Fasteners)
12	1	R18230-107	3 PH. Switch
13	1	R18230-110	1 PH. Switch
14	1	R18230-108	Check Valve (Valve, Seals)
15	1	R18230-111	3 PH. Contactor
16	1	R18230-193	Motor Assem. 1 PH.
17	1	R18230-194	Motor Assem. 3 PH.
18	1	R18230-235	Connector
19	1	R18230-236	Jumper Plug

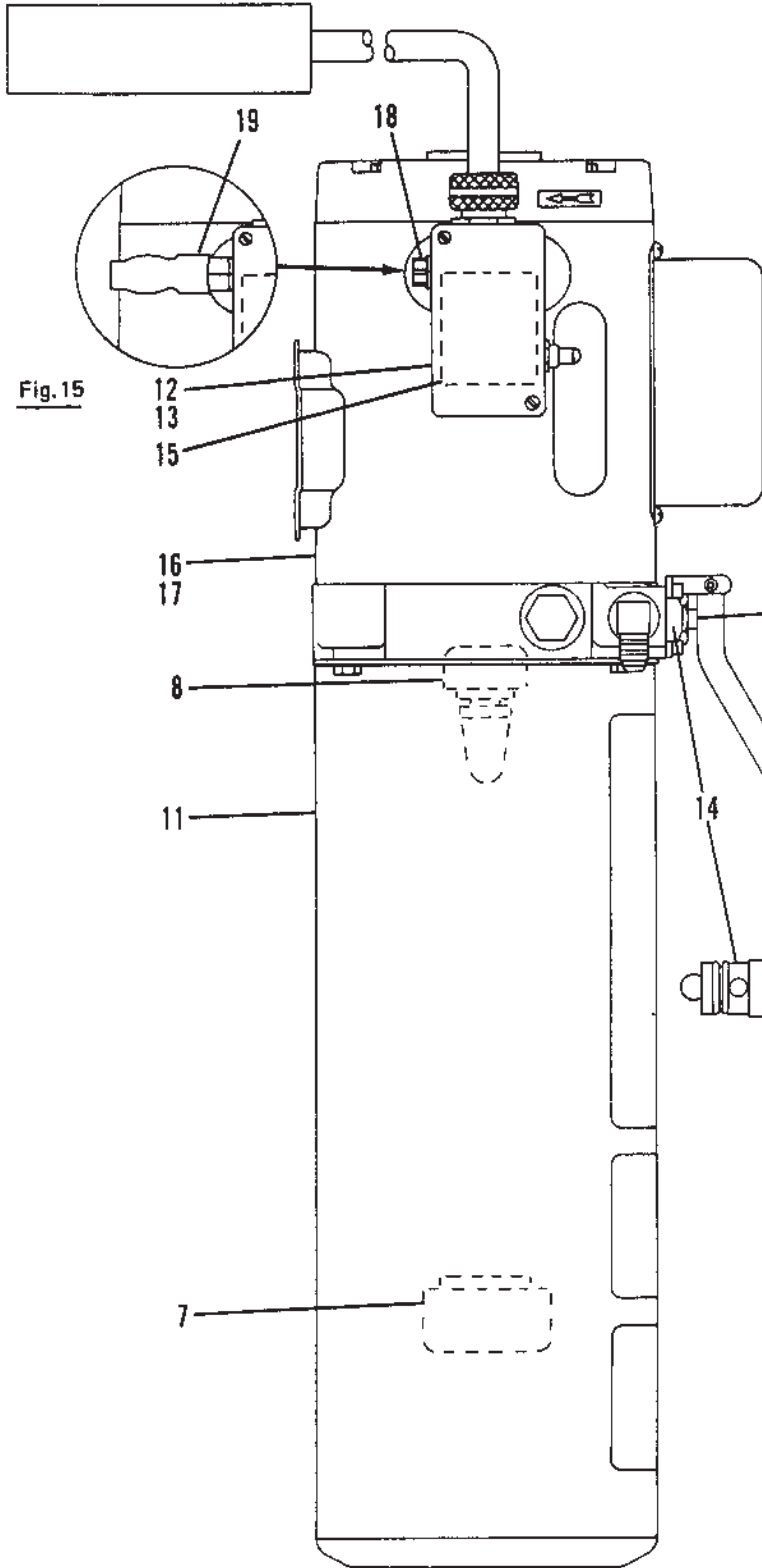
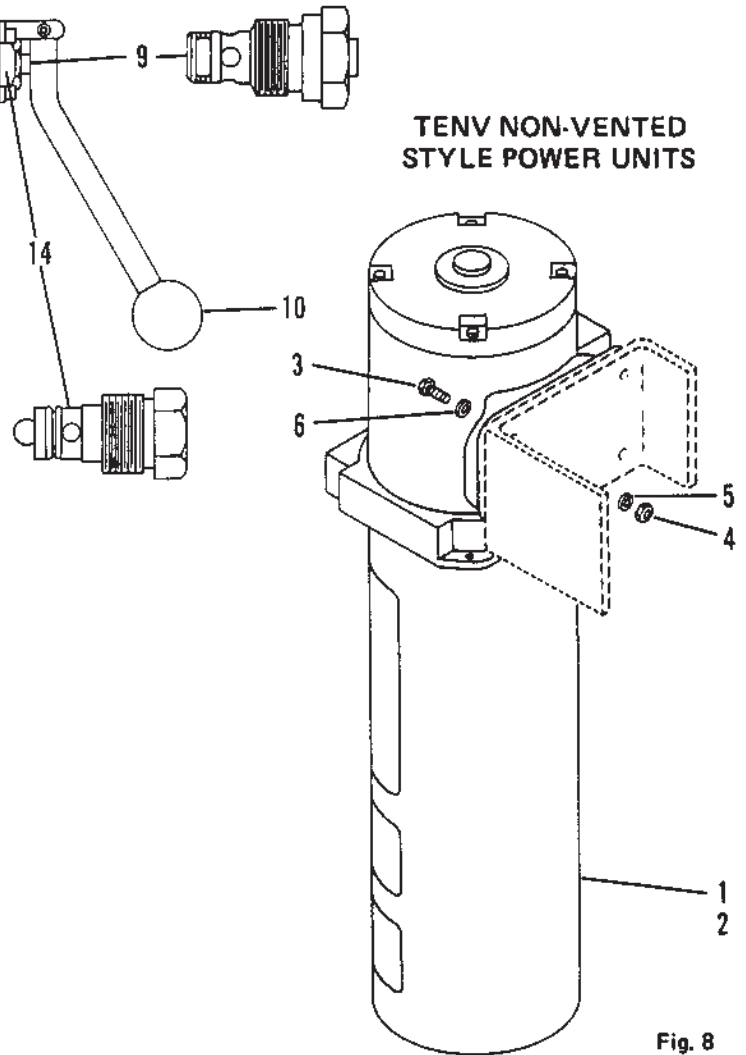

Fig. 15

BARNES POWER UNIT WITH FLUSH MOUNTED CONNECTOR

POWER UNIT

CBT-00



TENV NON-VENTED STYLE POWER UNITS

Fig. 8

PANZITTA SALES & SERVICE
 72 George Avenue
 Wilkes-Barre, PA 18705
 570-822-6720 800-822-6720
 www.panzittasales.com

When ordering replacement parts, always mention lift model number and serial number.

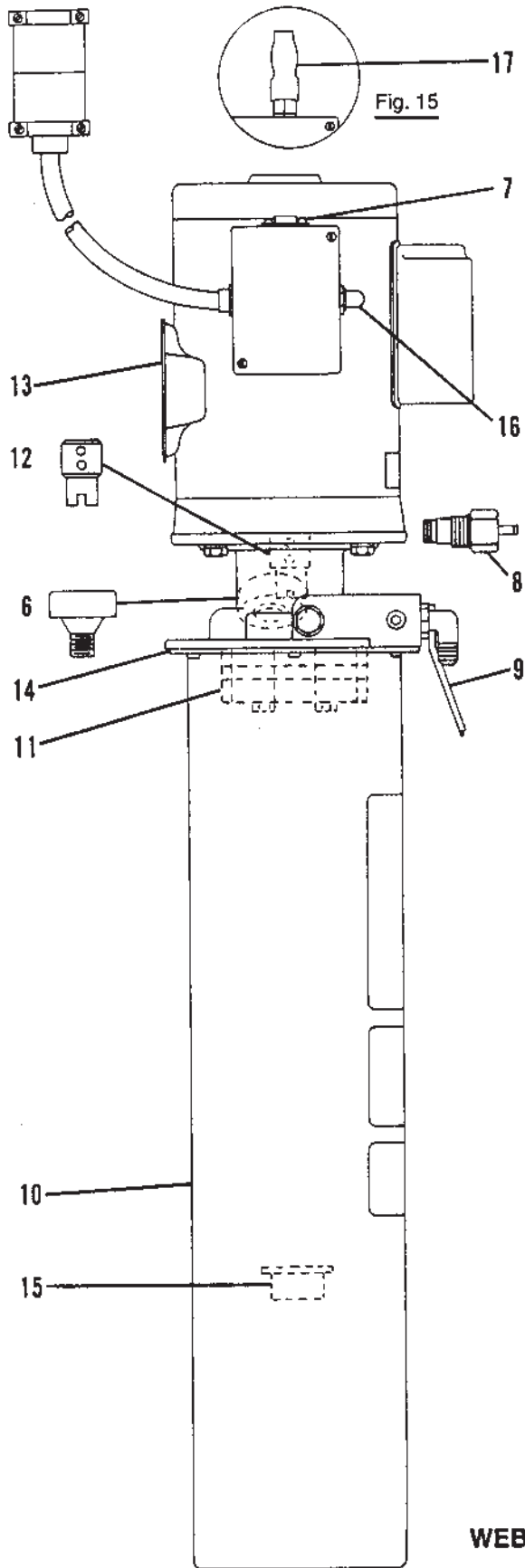

Item No.	No. Req.	Part No.	Description
1	1	K93272	Power Unit (208/230V., 1 PH.)
2	4	R18230-140	5/16-18 x 1" Bolt
3	4	R18230-141	5/16-18 Hex Nut
4	4	R18230-142	5/16 Dia. Lock Washer
5	4	R18230-143	5/16 Dia. Flat Washer
6	1	R18230-270	Breather
7	1	R18230-235	Connector
8	1	R18230-271	Manual Valve Assm.
9	1	R18230-272	Handle Kit
10	1	R18230-273	Tank Kit
11	1	R18230-274	Pump Assm.
12	1	R18230-275	Motor Hdwe. Kit
13	1	R18230-269	Motor Assm. 1 PH.
14	1	R18230-276	Tank Gasket
15	1	R18230-277	Inlet Strainer
16	1	R18230-278	Motor Switch Kit
17	1	R18230-236	Jumper Plug

