

# HYDRA-LIFT®

---

HYDRA-LIFT

## Parts List for 2 Post Model 29/31 1987

PANZITTA SALES & SERVICE  
72 George Avenue  
Wilkes-Barre, PA 18705  
570-822-6720 800-822-6720  
[www.panzittasales.com](http://www.panzittasales.com)

---

**HYDRA-LIFT®**



**HYDRA**



Manufacturer of Vehicle Service Equipment



**NOTE: ALL PART NUMBERS FOR MODELS 29 AND 31 ARE IDENTICAL WITH THE FOLLOWING EXCEPTIONS:**

MODEL-31 TOP BEAM ASSEMBLY  
 MODEL-31 CABLES  
 MODEL-31 OVER-RIDE CABLE  
 MODEL-31 LONG ARM ASSEMBLY  
 MODEL-31 SHORT ARM ASSEMBLY (LEFT)  
 MODEL-31 SHORT ARM ASSEMBLY (RIGHT)

PART NO. 31501 - 1 REQ'D.  
 PART NO. 31604 - 2 REQ'D.  
 PART NO. 31302 - 1 REQ'D.  
 PART NO. 31223 - 2 REQ'D.  
 PART NO. 31207 - 1 REQ'D.  
 PART NO. 31233 - 1 REQ'D.

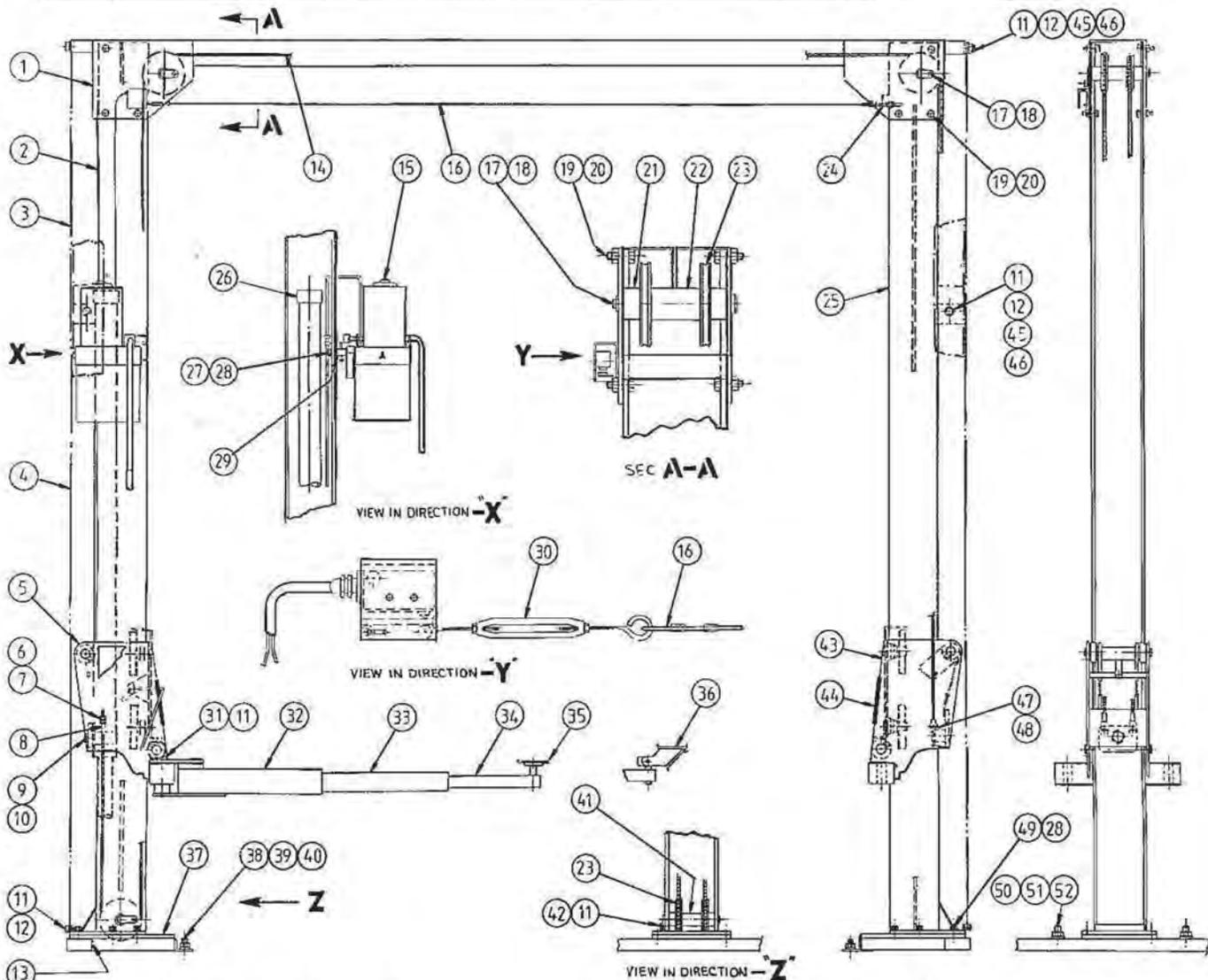

Sym	Qty	Part No.	Part Name
1	1	29040	Top Beam Assy.
2	1	29002	Power Column Weldment
3	2	29085	Shroud Extension
4	2	27150	Shroud
5	1	28004	Power Carriage Assy.
6	4	28496	5/8 UNF Hex Nut
7	2	28349	5/8 ID Flat Washer Small
8	4	28087	Spacer Cables
9	2	28490	1 UNC x 1-3/4 Lg. Hex. Bolt
10	2	28395	1 ID Lock Washer
11	16	28455	1/4 UNC x 1/2 Lg. Hex. Bolt
12	12	28339	1/4 ID Flat Washer Plated
13	1	28242	Serial Plate
14	2	29010	Cable Assy.
15	1	29200	Hydraulic Power Pack Assy.
16	1	29302	Override Cable Assy.
17	2	29092	Pivot Pin Sheaves
18	2	29451	5/16 UNC x 1/2 Lg. Hex. Bolt
19	12	29454	3/4 UNC x 2-1/4 Lg. Hex. Bolt
20	12	29480	3/4 UNC Nylock Lock Nut
21	4	29095	Spacer
22	2	29094	Spacer
23	6	28032	Sheave Assy.
24	1	29012	Spring Override
25	1	29035	Slave Column Weldment
26	1	28003	Hydraulic Ram Assy.

Sym	Qty	Part No.	Part Name
27	2	28495	5/8 UNC Hex. Nut
28	14	28348	5/8 ID Lock Washer
29	2	27160	Spacer Power Rack
30	1	29099	Turn Buckle
31	4	28088	Pivot Pin
32	4	28235	Arm Assembly
33	4	28235	Arm Assembly
34	4	28191	Low Profile Pad
35	4	28191	Low Profile Pad
36	4	NO. 30	High Lift Pad (optional)
37	2	29060	Base Weldment
38	2	48140	Lag Bolt
39	2	28495	5/8 UNC Hex. Nut Plated
40	2	28349	5/8 ID Flat Washer Plated
41	1	28031	Spacer
42	1	28065	Pivot Pin
43	1	29025	Slave Carriage Assy.
44	4	28189	Rubber Door Guard
45	8	28492	1/4 UNC Hex. Nut
46	8	48343	1/4 ID Lock Washer
47	2	28110	Clevis Pin
48	2	28498	3/32 Dia. x 1 Lg. Cotter Pin
49	12	28484	5/8 UNC x 1-1/2 Lg. Hex. HD Bolt
50	12	28115	Lag Bolt
51	12	70126	3/4 UNC Hex. Nut Plated
52	12	48342	3/4 ID Flat Washer Plated

### Slave Carriage Assembly No. 29025

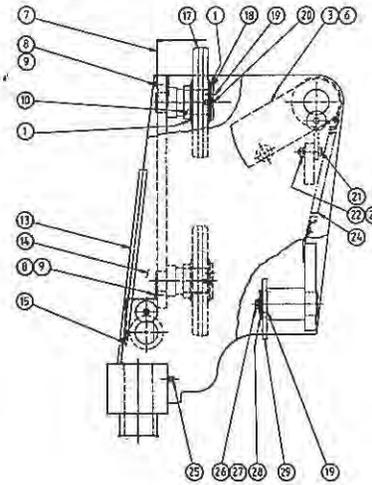
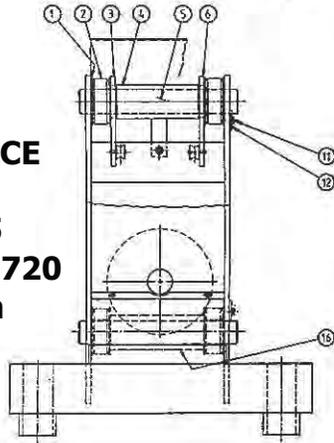

**PANZITTA SALES & SERVICE**  
 72 George Avenue  
 Wilkes-Barre, PA 18705  
 570-822-6720 800-822-6720  
 www.panzittasales.com

Sym	Qty	Part No.	Part Name
1	12	28006	Nylon Thrust Washer
2	4	28310	Main Roller Assy.
3	1	28062	Safety Dog Weldment (LH)
4	1	28050	Spacer Weldment Main Roller
5	2	28008	Shaft Main Roller
6	1	28057	Safety Dog Weldment (RH)
7	1	28178	Slave Carriage Top Roller Guard
8	4	28450	#10-32 Scr. x 1/2 Plated
9	4	28350	#10 Flat Washer
10	2	28013	Spacer Track Roller
11	2	28455	1/4-20 UNC x 1/2 Hex.HD. Bolt
12	2	28010	Keeper Main Roller
13	2	28189	Rubber Moulding Door Guard
14	1	29030	Slave Carriage Weldment
15	1	28179	Bottom Roller Guard

Sym	Qty	Part No.	Part Name
16	1	28012	Spacer Main Roller
* 17	2	28300	Track Roller
18	2	28011	Keeper Plate Track Roller
19	3	28499	1/8 Dia. x 1/2 Roll Pin
20	2	28465	5/16-18 x 3/4 Csk. Bolt
21	1	28466	5/16-18 x 1 Hex.HD Bolt
22	1	28493	5/16-18 Hex.Nut
23	1	28340	5/16 Lock Washer
24	2	28053	Tension Spring
25	2	28247	Grease Nipple
26	1	29452	1/2-13 x 3/4 Hex.HD. Bolt
27	1	29506	1/2 Lock Washer
28	1	29011	Keeper Plate
29	1	28056	Equalizer Plate

\* Specify Size

### Power Carriage Assembly No. 28004

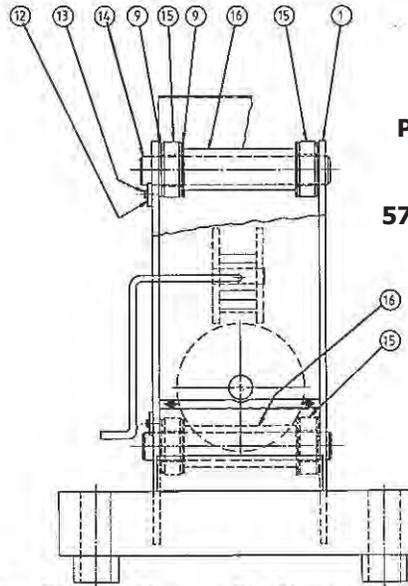
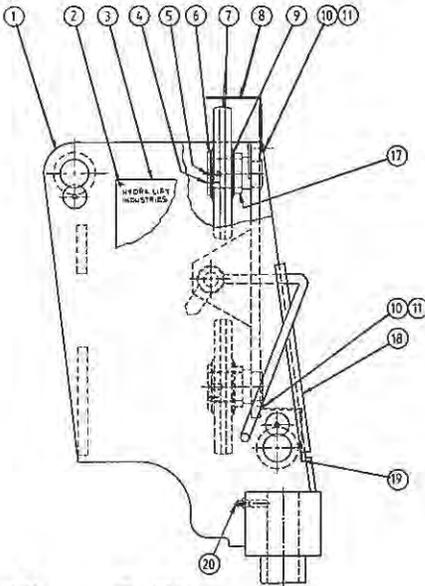

**PANZITTA SALES & SERVICE**  
 72 George Avenue  
 Wilkes-Barre, PA 18705  
 570-822-6720 800-822-6720  
 www.panzittasales.com

Sym	Qty	Part No.	Part Name
1	1	28014	Carriage Weldment
2	4	28239	Metal Tacks
3	1	28166	Maintenance Plate
4	2	28499	1/8 ø x 1/2 Lg. Roll Pin
5	2	28465	5/16 UNC x 3/4 Lg. CSK Bolt
6	2	28011	Keeper Plate Track Roller
* 7	2	28300	Track Roller Assy.
8	1	28177	Roller Guard Power Side
9	12	28006	Nylon Thrust Washer
10	4	28450	#10-32 x 1/2 Screw Plated

Sym	Qty	Part No.	Part Name
11	4	28350	#10 Flat Washer
12	2	28010	Keeper-Main Roller
13	2	28455	1/4-20 UNC x 1/2 Lg. Hex.Hd. Bolt
14	2	28008	Shaft-Main Roller
15	4	28310	Main Roller Assy.
16	2	28012	Spacer Tube-Main Roller
17	2	28013	Spacer-Track Roller
18	2	28189	Rubber Moulding Door Guard
19	1	28179	Bottom Roller Guard
20	2	28247	Grease Nipple

\*Specify Size

## Single Stage Hydraulic Cylinder Assembly No. 28003

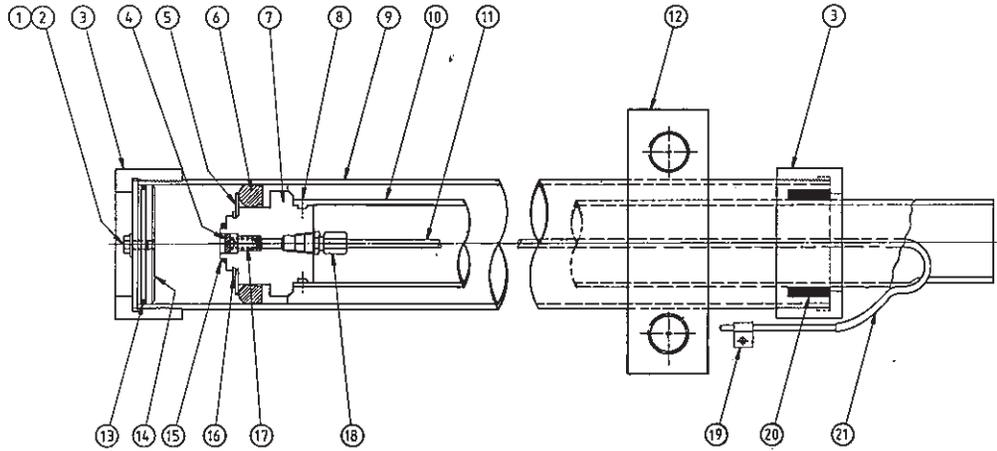

Sym	Qty	Part No.	Part Name
1	1	28460	1/4-28 UNF x 1/2 Hex Bolt
2	1	28104	1/4 Copper Washer
3	1	28094	Cylinder Cap
4	1	28099	Orifice
5	1	28096	Keeper Washer
6	1	28101	Seal & Wiper Ring
7	1	28093	Piston
8	3	28451	1/4-20 UNC x 3/8 Allen Hd. Set Screw
9	1	28090	Hydraulic Tube
10	1	28091	Piston Post

Sym	Qty	Part No.	Part Name
11	1	28106	Hydraulic Line Tube
12	1	28054	Lift Block
13	1	28102	"O" Ring
14	1	28095	Cylinder Plug
15	1	28100	1/16 $\phi$ x 1 Lg. Cotter Pin
16	1	28097	1-5/8 $\phi$ External Snap Ring
17	1	28098	Compression Spring
18	1	28105	Hydraulic Fitting
19	3	28108	Tube Clips
20	1	28103	Felt Strip
21	1	28107	Protector Tube

### 220 Volt Single Phase Wiring Diagram

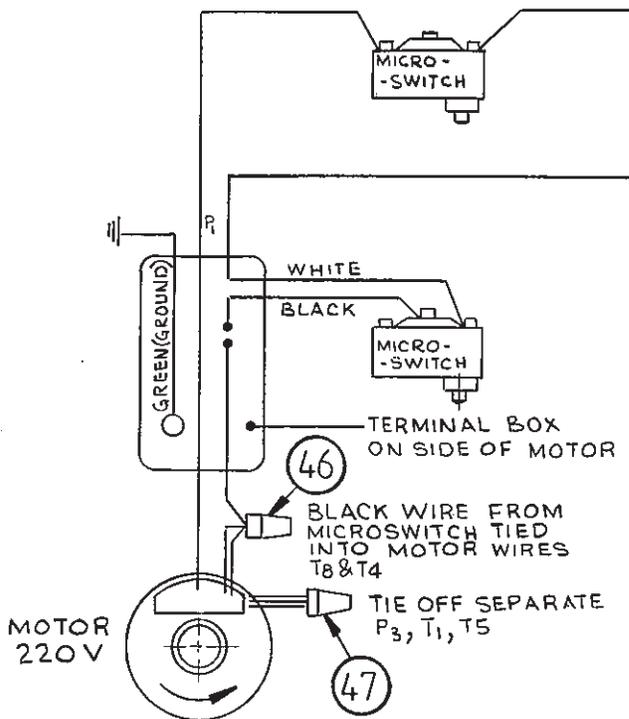

### 220/440/550 Volt Three Phase Wiring Diagram

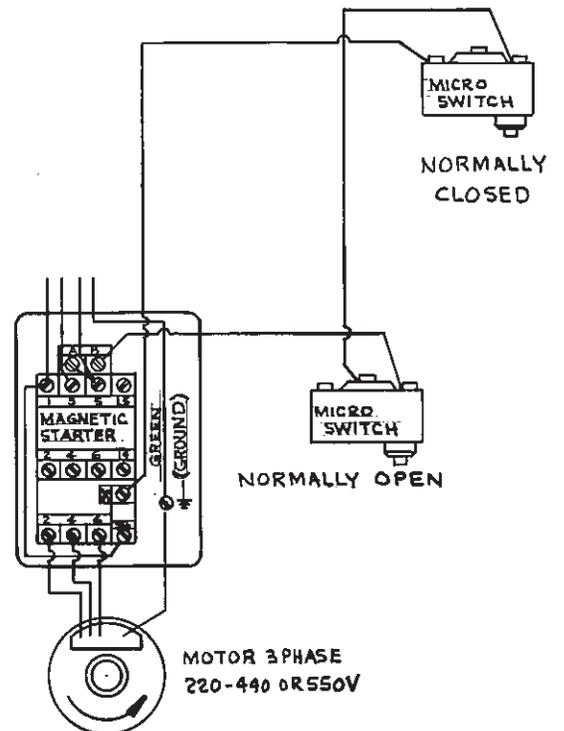

**PANZITTA SALES & SERVICE**  
**72 George Avenue**  
**Wilkes-Barre, PA 18705**  
**570-822-6720 800-822-6720**  
**www.panzittasales.com**

**NOTE**  
 SWITCH HEATERS AND AMP CONTROL MUST BE SUITABLE FOR VOLTAGE

# Hydraulic Power Pack Assembly

No. 29200 (220V/10)

No. 29199 (220V/30)

No. 29198 (550V/30)

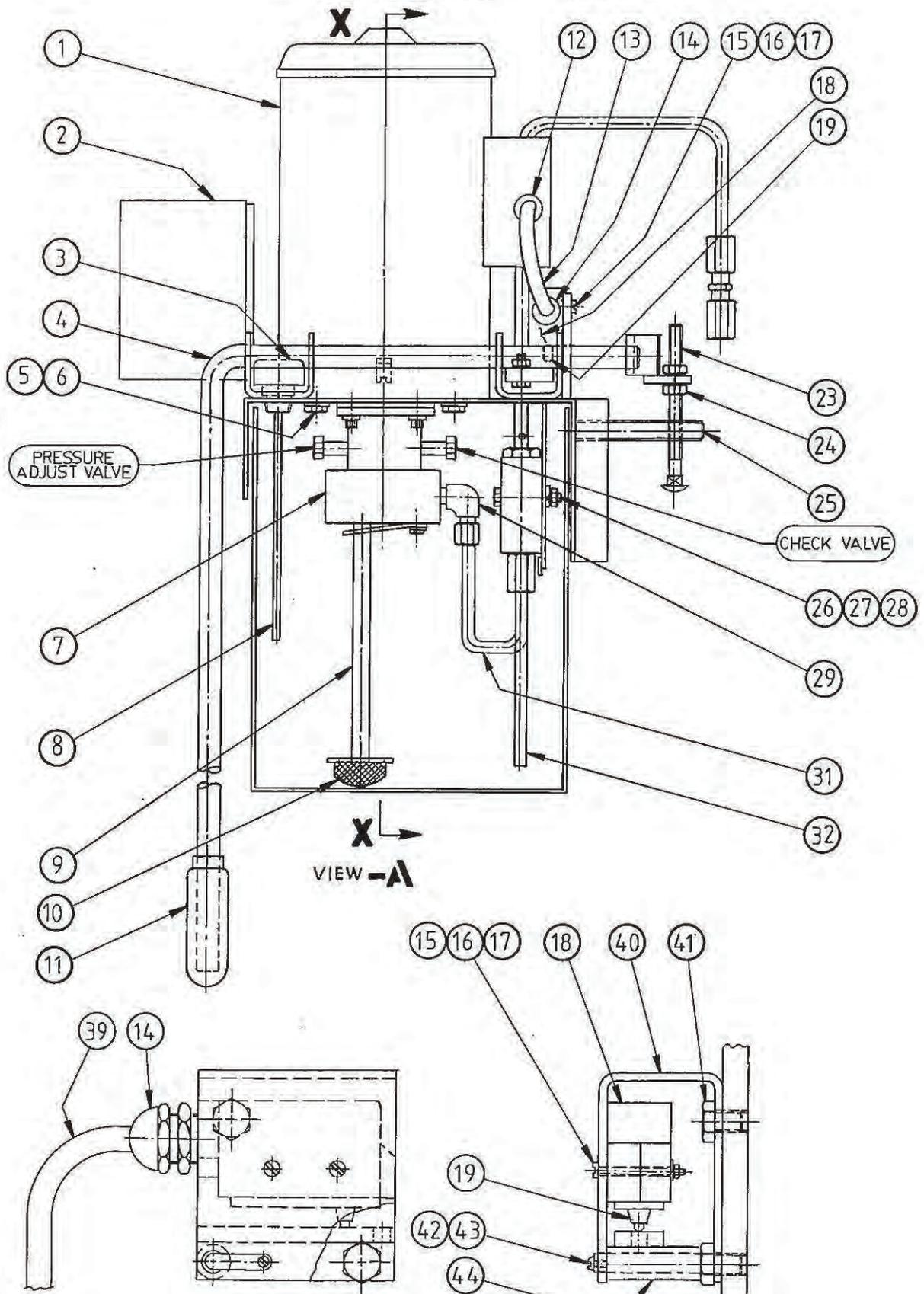

## Hydraulic Power Pack Assembly

**PANZITTA SALES & SERVICE**

**72 George Avenue**

**Wilkes-Barre, PA 18705**

**570-822-6720 800-822-6720**

**www.panzittasales.com**

**No. 29200 (220V/1Ø)**

**No. 29199 (220V/3Ø)**

**No. 29198 (550V/3Ø)**

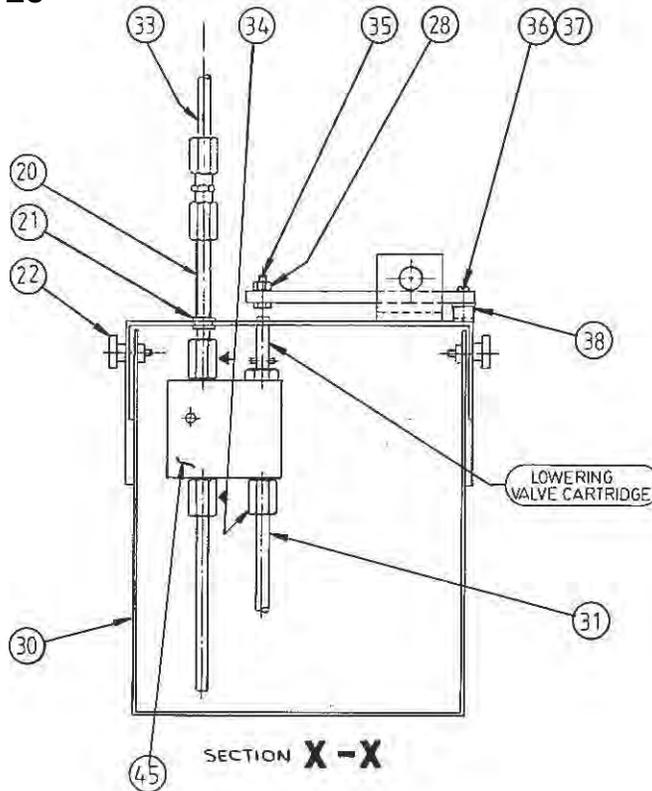

Sym	Qty	Part No.	Part Name	Sym	Qty	Part No.	Part Name
	1	27008	Drive Motor 220V/1Ø	25	2	27004	Mounting Stud
*	1	See Note	Magnetic Starter	26	1	28468	5/16-18 UNC x 1-3/4 Lg. Hex. Bolt
	1	28183	Breather	27	1	28343	5/16 Flat Washer
	1	27201	Power Unit Frame (Weldment)	28	2	28493	5/16-18 UNC Hex. Nut
	4	48450	3/8-16 UNC x 3/4 Lg. Hex. Bolt	29	1	27056	90° Male Elbow, 1/4 Pipe Thd.
	4	28345	3/8 Lock Washer	30	1	27214	Hydraulic Tank
**	1	27007	Hydraulic Pump Assy.	31	1	28156	Pressure Side Hyd. Line Tube
	1	28136	Oil Level Gauge	32	1	28157	Return Side Hyd. Line Tube
	1	27030	Intake Tube Weldment	33	1	29158	Hyd. Line Tube To Cylinder
	1	27005	Filter Screen	34	2	28105	Hydraulic Fitting
	1	28186	Handle Grip	35	1	28467	5/16-18 UNC x 3/4 Lg. Hex. Bolt
	1	28201	Strain Relief Bushing	36	1	28452	10-32 UNF x 3/4 Lg. RD HD Bolt
	1	28162	Electrical Wire	37	1	28491	10-32 UNF Hex. Nut
	2	28199	Liquid Tight Connector	38	1	28163	Rubber Bumper
	4	28500	6-32 UNC x 1-1/2 Lg. RD HD Bolt	39	1	29096	Electrical Wire
	4	28501	6-32 UNC Hex. Nut	40	1	29080	Micro Switch Bracket
	4	28502	6-32 Flat Washer	41	2	29323	5/16-18 UNC x 1/2 Lg. Hex. Bolt
	2	28145	Micro Switch Housing	42	1	29072	Pin Weldment
	2	28144	Micro Switch	43	1	28450	#10-32 UNC x 1/2 Lg. RD HD Bolt
	1	29303	Line Lowering Valve To Cylinder	44	1	29075	Pivot Lever Weldment
	1	28182	Grommet	45	1	28143	Lowering Valve
	2	28181	Thumb Screw	46	1	28197	Terminal Connector
	1	28802	1/2-13 UNC x 5 Lg. Carriage HD Sq Nec Bolt	47	1	28198	Orange Marrette Connector
	2	28480	1/2-13 UNC Hex. Nut				

\* For 220, 575 Three Phase Motors Only  
 \*\* Includes Gasket, Flange and Pump.

Part No.	Description	Qty.		Part No.	Description	Qty.
28194	220V, 3 Phase Motor	1	or	28195	575V, 3 Phase Motor	1
28155	Magnetic Starter	1		28603	Magnetic Starter	1
28158	3/8 Conseal x 12" Long	1		28158	3/8 Conseal x 12" Long	1
28160	90° x 3/8 Liquid Tight Electrical Connector	2		28160	90° x 3/8 Liquid Tight Electrical Connector	2