

ADAPTER PARTS - 3 POSITION
 (FOR 1-5/8" x 6" ARM)

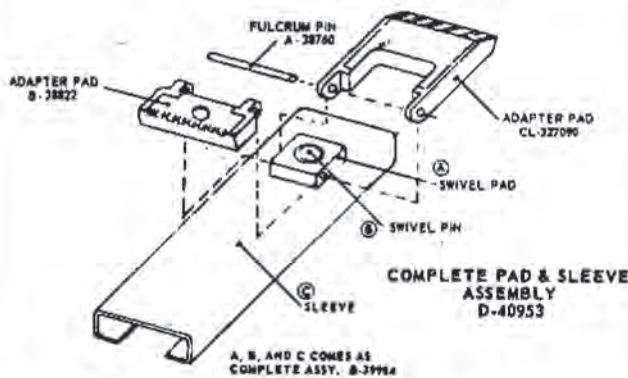

STABILIZER ASSEMBLY
 (WITH 83-1/2" POST CENTERS)

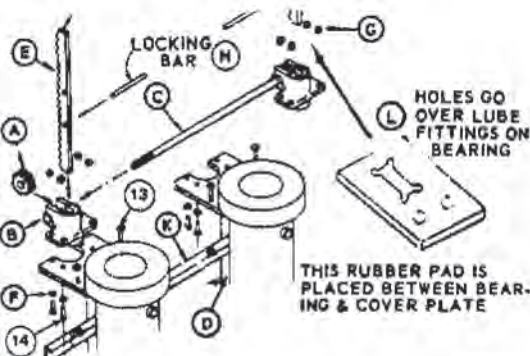

PARTS LIST

Ref.	Quan.	Part No.	Description
1	(2)	C-39978	8-1/2" Cylinder Assembly
	(2)	B-37500	Cylinder Casing Only
	(2)	B-37442-4	Plunger Assembly Only
2	(1)	C-39971	Bolster Left Hand
3	(1)	C-39971-1	Bolster Right Hand
4	(4)	B-39973	Swivel Arms
5	(4)	D-40953	Pad & Sleeve Assembly
6	(2)	B-39086	Stabilizer Housing
7	(2)	B-39818	Stabilizer Rack
8	(1)	B-39981	Pitform Assebmly
	(1)	B-33207-6	Stabilizer Shaft
	(2)	B-41384	Stabilizer Bkt. Assembly
	(2)	B-39999	Stabilizer Gear Assembly
	(1)	B-35365-8	Cylinder Spacer Channel
	(1)	B-35366-6	Cylinder Spacer Angle
	(1)	B-37905-3	Fill Plug
	(1)	B-37904-1	Gauge Stick Assembly
	(1)	B-30709	Positioning Rod
	(2)	B-33243-6	Locking Bar 9/19" x 10"
(1)	CL-326910	Wheel Stop	
(4)	A-40690	5/16" x 1-1/2" Rawl Drive	
9	(2)	913931	Hex Hd. Scr. 5/8"-11NC x 1-3/4"
9A	(2)	913932	Washer
10	(4)	513149	5/8"-11NC x 1-3/4" Soc. Hd. Cap
11	(4)	A-40689	Arm Pivot Spacer
12	(4)	B-32101-2	Arm Pivot Washer
13	(4)	430xE16	Hex. Hd. Screws 1/2"-13 NC x 2"
14	(8)	430xE18	Hex. Hd. Scr. 1/2"-13NC x 2-1/4"
15	(8)	438xH28	3/4"-10NC x 3-1/2" Soc. Hd. Cap Screws

See Detail Below

STABILIZER PARTS (FOR 83-1/2" POST CENTERS)

A	(2)	B-39999	Stabilizer Gear
B	(2)	B-41384	Stabilizer Bkt. Assembly
C	(1)	B-33207-6	Stabilizer Shaft (88-1/2" Lg.)
D	(2)	B-39086	Stabilizer Housing
E	(2)	B-39818	Stabilizer Rack
F	(8)	635x10	1/2" Lock Washers
G	(8)	285x5	1/2"-13NC Hex Nuts
H	(2)	B-33243-6	Locking Bar
J	(1)	B-35365-8	Cylinder Spacer Channel (99" Lg.)
K	(1)	B-35366-6	Cylinder Spacer Angle (101-3/8" Lg.)
L	(2)	B-37980	Rubber Grommet

NOTE: When ordering replacement stabilizer system parts please give distance between Q_L of cylinders