

PANZITTA SALES & SERVICE
72 George Avenue
Wilkes-Barre, PA 18705
570-822-6720 800-822-6720
www.panzittasales.com

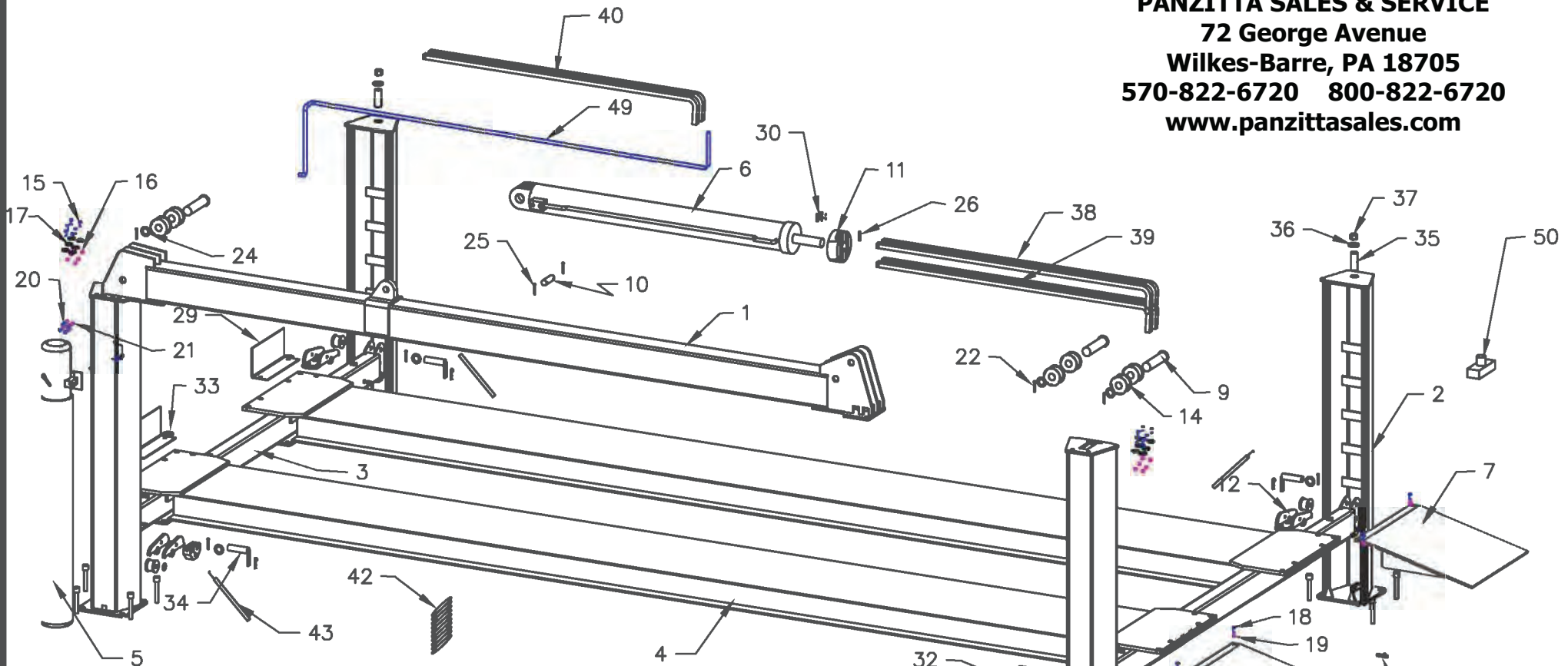

INDEX NO.	DESCRIPTION	PART NO.	Q'TY
-1	POWER BEAM	5210472	1
-2	POST	5210490	4
-3	CROSS TUBE	5210488	2
-4	RAMP	5210875	2
-5	POWER UNIT		1
-6	CYL.5 x70	5502155	1
-7	DRIVE UP RAMP	5210481	2
-8			
-9	ROLLER SHAFT		3
-10	1 1/4x4 CYL.PIN		1
-11	CYL.CHAIN CONN.	5746405	1
-12	SAFETY	5210486	4
-13	CROSS TUBE CONN.	5736335	2
-14	SHEAVE ROLLER	5575215	10
-15	1/2-13x2HHB	5530225	12
-16	1/2-13 HEX NUTS	5535160	12
-17	1/2 LOCK WASHERS	5545125	12
-18	3/4-10x2 HHB	5530215	4
-19	3/4-10 HEX NUT	5535155	4
-20	5/16-18x3/4 HHB	5530260	4
-21	5/16-18 HEX NUTS	5535165	4
-22	COTTER PIN 3/16x2 1/2	5505405	9
-23	C- SHIMS	5545535	25
-24	1 3/8 FLAT WASHER	5545163	7
-25	COTTER PIN 1/4x3	5505681	1
-26	5/16x2 DOWELL PIN	5505590	8

INDEX NO.	DESCRIPTION	PART NO.	Q'TY
-27	90FIT.	5550134	1
-28	ANCHOR BOLTS 3/4x4 3/4	5530455	16
-29	TIRE STOPS	5700630	2
-30	BL-646 CONN. LINKS	5510320	2
-31	45 FITT.6802-8-6	5550143	2
-32	HAIRPIN #203	5505335	12
-33	1/2 FLAT WASHER	5545180	4
-34	CROSS TUBE PIN	5505205	4
-35	CHAIN CONN.	5746325	2
-36	1 1/2 FLAT WASHERS	5545160	2
-37	1 1/2-12 NYLOCK NUT	5535125	2
-38	BL-646 336 3/4 LONG	5510450	2
-39	BL-646 104 1/4 LONG	5510370	2
-40	BL-646 213 3/4 LONG	5510470	2
-41	1/4 POLY HOSE 580 L.	5570795	1
-42	1/4 AIR BLUE HOSE	5570785	1
-43	AIR CYL.	5502320	4
-44	1/4 BELL REDUCER	5550405	2
-45	1/8 NPT NIPPLE	5550380	2
-46	BULK HEAD FITTING	5550370	1
-47	1/4" T TO 3/8	5550132	1
-48	AIR VALVE	5590175	1
-49	1/2 HYD. HOSE 105" LG	5570845	2
-50	FLOW CONTROL	5590115	1
-51	FITTING 6405-6-6	5550142	1
-52			

9-ROLLER SHAFT - IF 3/4" DIA 3181979, IF 1-3/8" DIA 3181980

 PROJECTION APPROVED	TOLERANCES: .XX ± 0.02 .XXX ± 0.005 FRACTIONS ± 1/16 SURFACE 63 DIA. Ø ±.005 ANGLES ± 1/2° QTY REQ'D	BEND-PAK 1645 LEMONWOOD DRIVE SANTA PAULA, CA 93060	
		BP-27	
		MAT'L:	
		DATE: 08/08/03	REV.
GAGE CODE ØA223	NEXT ASSY	SCALE: 1/15	BP-27

NOTES: UNLESS OTHERWISE SPECIFIED