

PANZITTA SALES & SERVICE  
72 George Avenue  
Wilkes-Barre, PA 18705  
570-822-6720 800-822-6720  
www.panzittasales.com

**WALKER**

**SERVICE  
DIVISION**

## Jack Parts Sheet

**MODEL 93636  
SERIES "A" & "B"**

**1 TON CAPACITY  
HYDRAULIC SERVICE JACK**

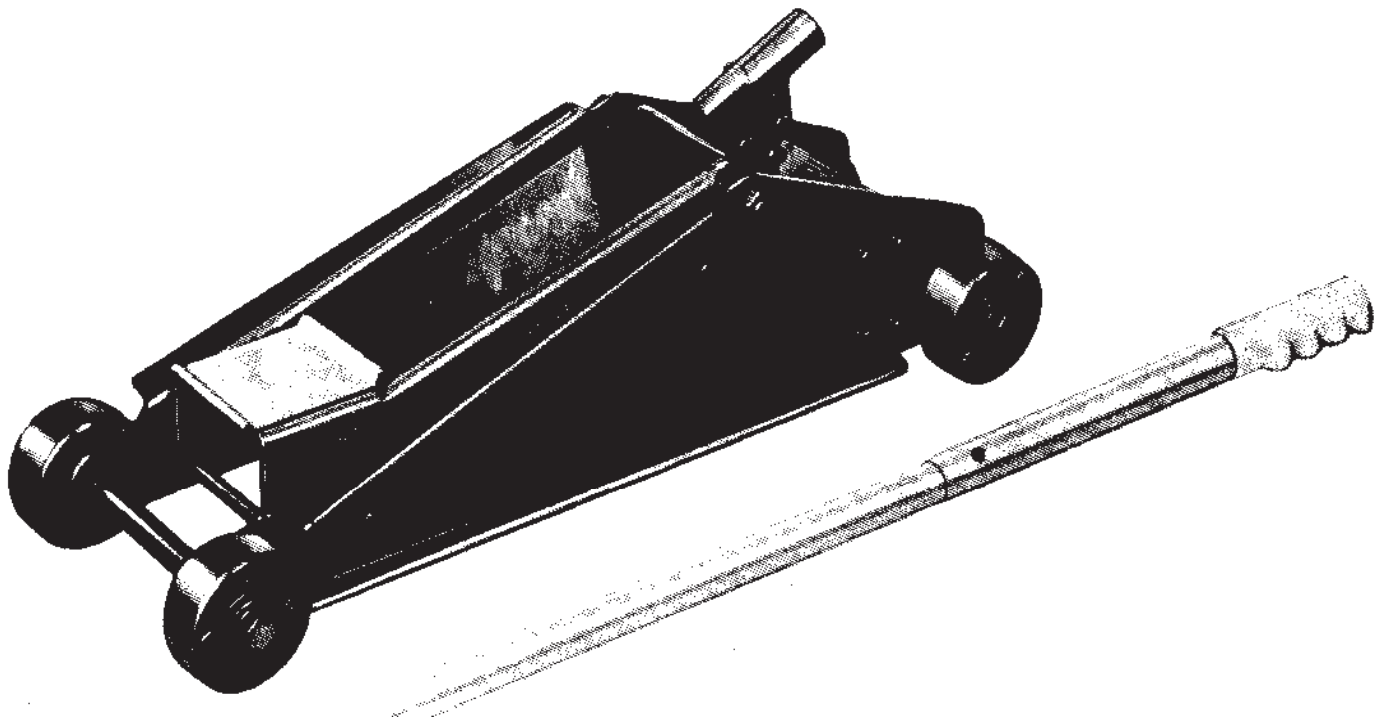

**MODEL 93636**

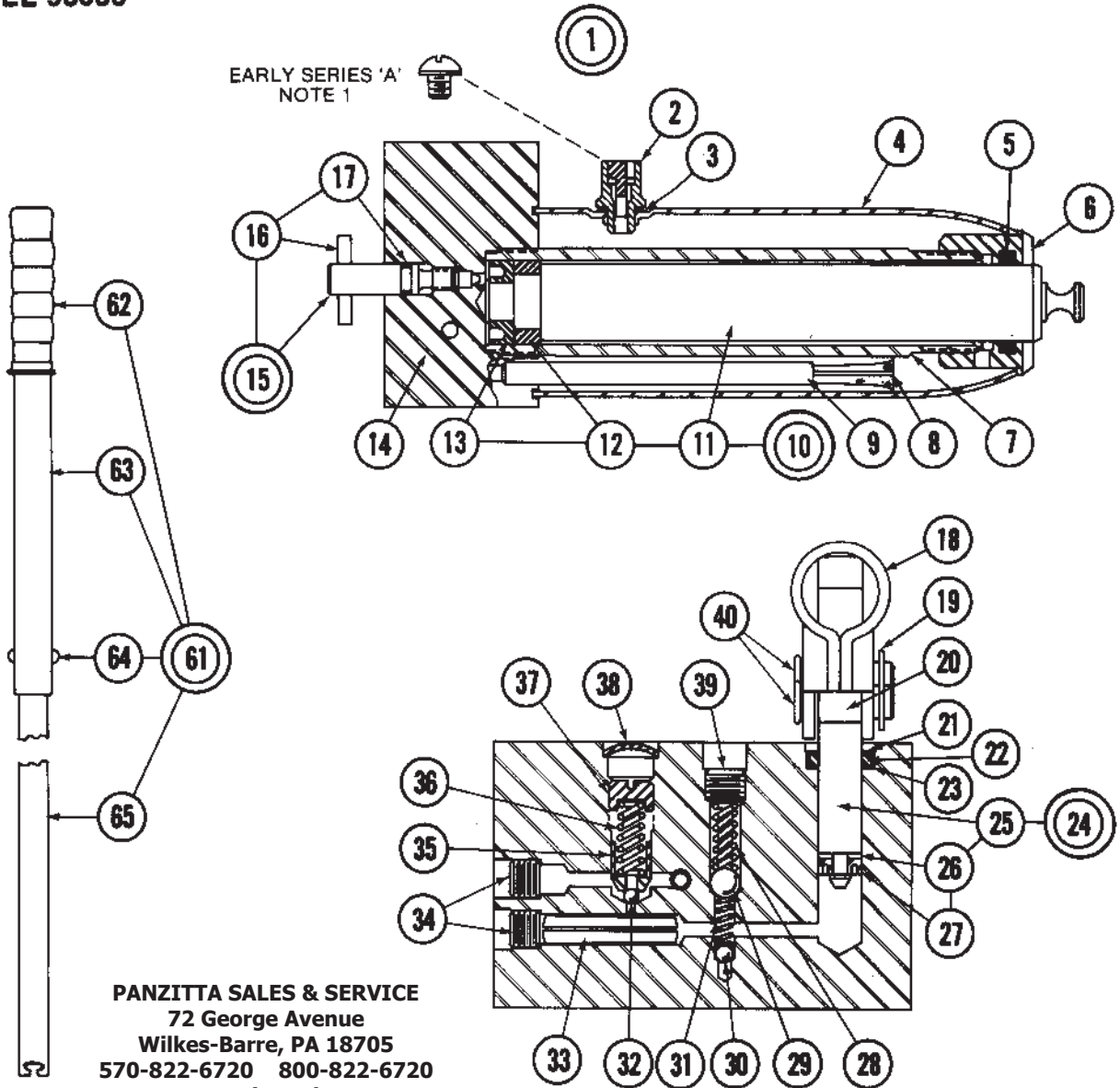

**PANZITTA SALES & SERVICE**  
 72 George Avenue  
 Wilkes-Barre, PA 18705  
 570-822-6720 800-822-6720  
 www.panzittasales.com

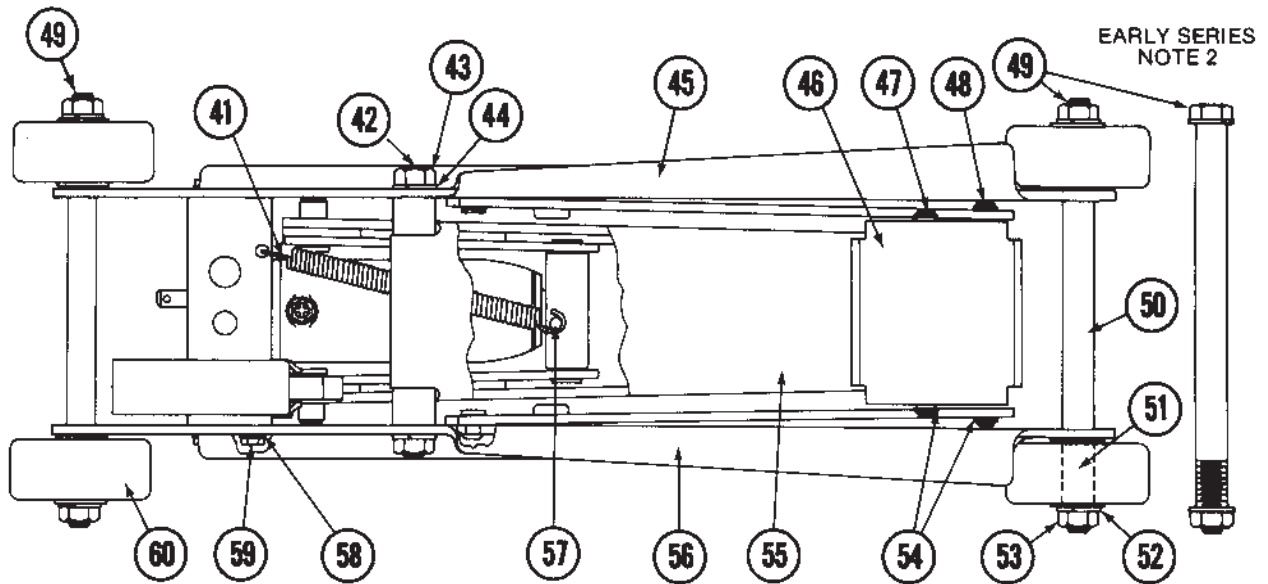

ORDER BY PART NUMBER NOT CODE NUMBER  
 SEE BACK PAGE FOR COMPLETE NUMERICAL LISTING

**MODEL 93636**

Code No.	Part Number	Description	No. Req'd.	Code No.	Part Number	Description	No. Req'd.
1	230538	Hydraulic Unit Assy.	1	36	226375	Spring	1
2	231316	Filler Plug Assy. (Note 1)	1	37	226373	Adjusting Nut	1
3	200003	Gasket	1	38	201733	Expansion Plug	1
4	230546	Oil Tank	1	39	210311	Pipe Plug	1
5	226744	Quad Ring	1	40	230539	Pin	2
6	226739	Tank Nut	1	41	230558	Pull Back Spring	1
7	230547	Cylinder	1	42	230567	Fulcrum Pin	1
8	231167	Suction Screen	1	43	203348	Nut	2
9	230582	Suction Tube	1	44	225254	Lockwasher	2
10	230581	Ram Assy.	1	45	230569	L.H. Side Plate Assy.	1
11	230548	Ram	1	46	230560	Lift Cap	1
12	224758	Heel Plate	1	47	230561	Pin	1
13	228255	"U" - Cup	1	48	230562	Pin	1
14	230540	Unit Block Assy.	1	49	231061	Axle (Note 2)	2
15	230819	Release Stem Assy.	1	50	230566	Spacer - Side Plates	2
16	217650	Roll Pin	1	51	230564	Spacer - Wheel	4
17	214555	"O" Ring	1	52	225254	Lockwasher (Note 2)	4
18	230754	Handle Socket	1	53	203348	Nut (Note 2)	4
19	220018	Retaining Ring	2	54	230574	Retaining Ring	4
20	209910	Pump Clip	1	55	230550	Bell Crank Assy.	1
21	216258	Pump Gland Cover	1	56	230568	R.H. Side Plate Assy.	1
22	213149	Packing Ring	1	57	230559	Pin	1
23	204281	Washer	1	58	201081	Lockwasher	8
24	226075	Pump Assy.	1	59	212566	Bolt	8
25	226179	Piston	1	60	230565	Wheel	4
26	214161	Leather Washer	1	61	231037	Handle Assy.	1
27	214154	"U" - Cup	1	62	231239	Handle Grip	1
28	222201	Spring	1	63	230575	Grip End	1
29	203201	Ball	1	64	221509	Pin	1
30	203197	Ball	1	65	230576	Release End	1
31	217909	Spring	1				
32	203196	Ball	1				
33	225251	Groove Pin	1				
34	210311	Pipe Plug	2				
35	226376	Adapter	1				

Note 1 - Early Series "A" used a vent screw. Reorder 231316 Filler Plug Assy.

Note 2 - Early production axle was a headed bolt with 225254 washer and 203348 nut.

When replacing axle on early production, re-order 231061 axle with 2-225254 washers and 2-203348 nuts.

**PANZITTA SALES & SERVICE**  
**72 George Avenue**  
**Wilkes-Barre, PA 18705**  
**570-822-6720 800-822-6720**  
**www.panzittasales.com**

**MODEL 93636**

**NUMERICAL LISTING OF PARTS**

Part No.	Code No.	Part No.	Code No.	Part No.	Code No.	Part No.	Code No.
200003	3	222201	28	230559	57	231239	62
201081	58	224758	12	230560	46	231316	2
201733	38	225251	33	230561	47		
203196	32	225254	44, 52	230562	48		
203197	30	226075	24	230564	51		
203201	29	226179	25	230565	60		
203348	43, 53	226373	37	230566	50		
204281	23	226375	36	230567	42		
209910	20	226376	35	230568	56		
210311	34, 39	226739	6	230569	45		
212566	59	226744	5	230574	54		
213149	22	228255	13	230575	63		
214154	27	230538	1	230576	65		
214161	26	230539	40	230581	10		
214555	17	230540	14	230582	9		
216258	21	230546	4	230574	18		
217650	16	230547	7	230819	15		
217909	31	230548	11	231037	61		
220018	19	230550	55	231061	49		
221509	64	230558	41	231167	8		

**Label Locations**

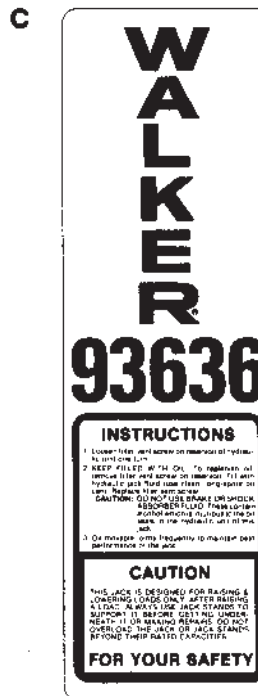
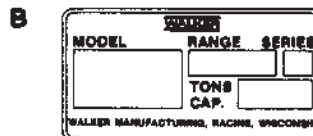
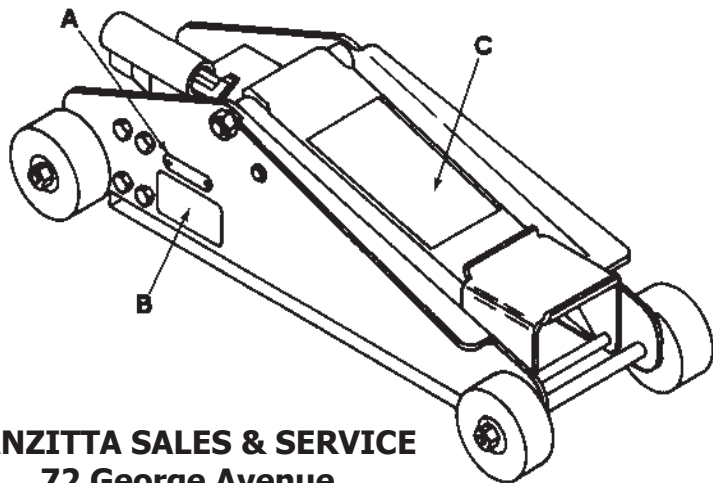

**PANZITTA SALES & SERVICE**  
72 George Avenue  
Wilkes-Barre, PA 18705  
570-822-6720 800-822-6720  
www.panzittasales.com